



Copier Feature Expander Type 3800C

| | |
|---------------------------------------|-----------|
| Introduction | 5 |
| Notice | 7 |
| How to Read this Manual | 8 |
| Manuals for This Machine..... | 10 |
| Advanced Features (this manual) | 10 |
| Basic Features..... | 10 |

1. Advanced Copying/Edit Image

| | |
|---|-----------|
| Size Magnification | 11 |
| Directional Magnification (%) | 14 |
| Directional Size Magnification (Inch)..... | 17 |
| Series | 20 |
| Erasing Colors | 23 |
| Erase | 25 |
| Border Erase | 26 |
| Center Erase | 28 |
| Center/Border Erase | 29 |
| Margin Adjustment | 32 |
| Image Repeat | 35 |
| Whole Area Repeat | 36 |
| Specified Area Repeat | 37 |
| Double Copies | 40 |
| Centering | 42 |



| | |
|--|-----------|
| Cover | 44 |
| Front Cover..... | 44 |
| Front/Back Covers..... | 46 |
| Slip Sheets | 49 |
| Storing the File in the Document Server | 51 |
| Programs | 53 |
| Storing a Program..... | 54 |
| Deleting a Program..... | 56 |
| Recalling a Program | 57 |
| Changing a Program's Name | 58 |
| User Color | 59 |
| Mixing Colors Manually with the Number Keys | 62 |
| Deleting User Colors | 64 |
| Sampling the User Colors..... | 65 |
| Job Preset | 66 |
| Other Functions | 68 |
| Energy Saver Mode | 68 |
| Auto Start | 68 |
| Interrupt Copy | 69 |
| Sample Copy | 70 |
| Combination Chart | 72 |





2. Troubleshooting

| | |
|---|-----------|
| If You Cannot Make Clear Copies..... | 74 |
| When copying doesn't start | 77 |
| When a Message is Displayed..... | 77 |
| If You Cannot Make Copies As You Want..... | 79 |
| General | 79 |
| Adjust Image | 80 |
| Combine | 81 |
| Duplex | 82 |
| When Memory Is Full | 83 |
| Copy Quality | 85 |
| Auto Color Calibration..... | 88 |
| Adjust Color..... | 92 |
| Color Balance..... | 94 |
| Color Balance Program | 95 |

3. User Tools (Copier/Document Server Features)

| | |
|--|------------|
| Accessing the User Tools (Copier/Document Server Features)..... | 101 |
| Exiting From the User Tools | 102 |
| General Features ¹/₅..... | 103 |
| General Features ²/₅..... | 106 |
| General Features ³/₅..... | 108 |



| | |
|---|------------|
| General Features ⁴/₅ | 109 |
| General Features ⁵/₅ | 110 |
| Reproduction Ratio ¹/₂ | 111 |
| Reproduction Ratio ²/₂ | 113 |
| Edit ¹/₂ | 115 |
| Edit ²/₂ | 118 |
| Input/Output | 124 |
| Adjust Color Image | 127 |

4. Specifications

| | |
|--|------------|
| Mainframe | 128 |
| Originals | 131 |
| Sizes and Weights of Recommended Originals | 131 |
| Sizes Detectable by the Auto Paper Select..... | 132 |
| Letterhead | 137 |
| INDEX | 138 |





Introduction

This manual contains detailed instructions on the operation and maintenance of this machine. To get maximum versatility from this machine all operators should carefully read and follow the instructions in this manual. Please keep this manual in a handy place near the machine.

Please read “Safety Information” in Administrator Reference 1 Copier System Edition before using this machine. It contains important information related to USER SAFETY and PREVENTING EQUIPMENT PROBLEMS.

 **Notes**

Some illustrations may be slightly different from your machine.

Certain options may not be available in some countries. For details, please contact your local dealer.

Fax options are not sold in some areas.

Operator Safety

This machine is considered a CDRH class 1 laser device, safe for office/EDP use. The machine contains two 7-milliwatt, 645-660 nanometer wavelength, GaAIAs laser diodes. Direct (or indirect reflected) eye contact with the laser beam might cause serious eye damage. Safety precautions and interlock mechanisms have been designed to prevent any possible laser beam exposure to the operator.

Laser Safety:

The Center for Devices and Radiological Health (CDRH) prohibits the repair of laser-based optical unit in the field. The optical housing unit can only be repaired in a factory or at a location with the requisite equipment. The laser subsystem is replaceable in the field by a qualified Customer Engineer. The laser chassis is not repairable in the field. Customer engineers are therefore directed to return all chassis and laser subsystems to the factory or service depot when replacement or the optical subsystem is required.



Important

Contents of this manual are subject to change without prior notice. In no event will the company be liable for direct, indirect, special, incidental, or consequential damages as a result of handling or operating the machine.

Warning:

Use of controls or adjustment or performance of procedures other than those specified in this manual might result in hazardous radiation exposure.

Do not attempt any maintenance or troubleshooting other than that mentioned in this manual. This machine contains a laser beam generator and direct exposure to laser beams can cause permanent eye damage.

Two kinds of size notation are employed in this manual. With this machine refer to the inch version.

For good copy quality, the supplier recommends that you use genuine toner from the supplier.

The supplier shall not be responsible for any damage or expense that might result from the use of parts other than genuine parts from the supplier with your office product.

Power Source

120V, 60Hz, 12A or more

Please be sure to connect the power cord to a power source as above.



Notice

⚠ CAUTION:

Use of controls, adjustments or performance of procedures other than those specified herein may result in hazardous radiation exposure.

Shielded interconnect cables must be employed with this equipment to ensure compliance with the pertinent RF emission limits governing this device.

Direct (or indirect reflected) eye contact with the laser beam may cause serious eye damage. Safety precautions and interlock mechanisms have been designed to prevent any possible laser beam exposure to the operator.



How to Read this Manual

Symbols

The following set of symbols is used in this manual.

WARNING:

This symbol indicates a potentially hazardous situation that might result in death or serious injury when you misuse the machine without following the instructions under this symbol. Be sure to read the instructions, all of which are described in the Safety Information section.

CAUTION:

This symbol indicates a potentially hazardous situation that might result in minor or moderate injury or property damage that does not involve personal injury when you misuse the machine without following the instructions under this symbol. Be sure to read the instructions, all of which are described in the Safety Information section.

* The statements above are notes for your safety.

Important

If this instruction is not followed, paper might be misfed, originals might be damaged, or data might be lost. Be sure to read this.

Preparation

This symbol indicates information or preparations required prior to operating.

Note

This symbol indicates precautions for operation, or actions to take after abnormal operation.





Limitation

This symbol indicates numerical limits, functions that cannot be used together, or conditions in which a particular function cannot be used.

Reference

This symbol indicates a reference.

[]

Keys that appear on the machine's display panel

【 】

Keys built into the machine's control panel





Manuals for This Machine

Two manuals are provided for this machine, the Advanced Features manual (this manual) and the Basic Features manual. Please refer to the manual that suits your needs.

Advanced Features (this manual)

The Advanced Features manual describes more advanced functions and also explains settings for key operators.

Basic Features

The Basic Features manual explains the most frequently used copy functions and operations.

❖ Chapter 1 Basic Copying

Describes basic functions such as Reduce/Enlarge and Duplex copying, as well as how to start this machine and place the originals.





1. Advanced Copying/Edit Image

Size Magnification

This function calculates an enlargement or reduction ratio based upon the lengths of the original and copy.

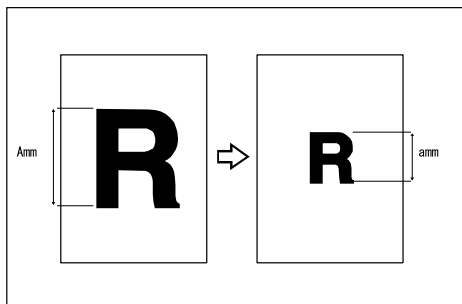

Preparation

Measure and specify the lengths of the original and copy by comparing “A” with “a.”.

Limitation

- If the calculated ratio is over the maximum or under the minimum ratio, it is adjusted to within the available range of ratios automatically. However, with some ratios, parts of the image might not be copied or margins will appear on copies.

Note

- A ratio is selected in the range of 25 to 400%.

1 Press [Reduce/Enlarge].

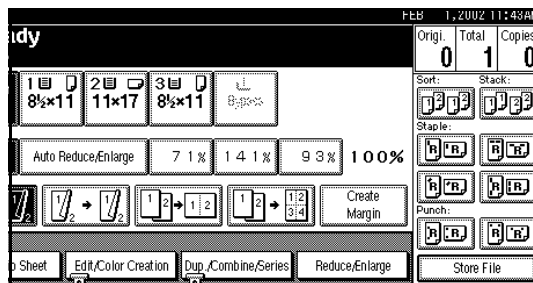

2 Press [Specify Ratio].

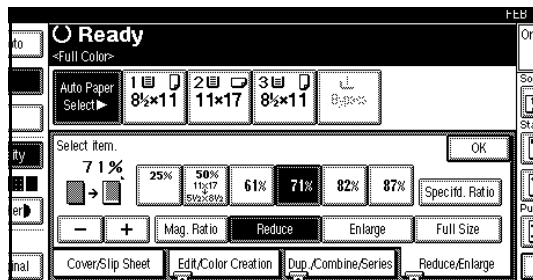



3 Make sure that [Size Magnificatn] is highlighted.

4 Enter the length of the original with the number keys, and then press [#].

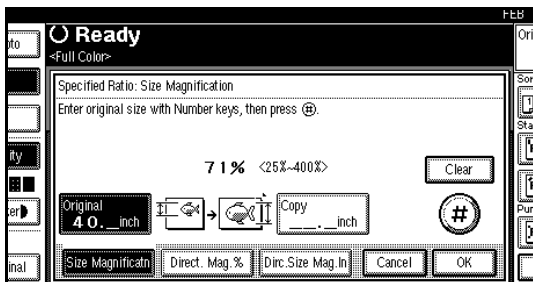

Note

- You can enter sizes within the following ranges:

| | |
|----------------|------------------------------|
| Metric version | 1 – 999mm (in 1mm steps) |
| Inch version | 0.1" – 99.9" (in 0.1" steps) |

- To change the length entered, press [Clear] or the [Clear/Stop] key, and then enter the new length.

5 Enter the length of the copy with the number keys, and then press [#].

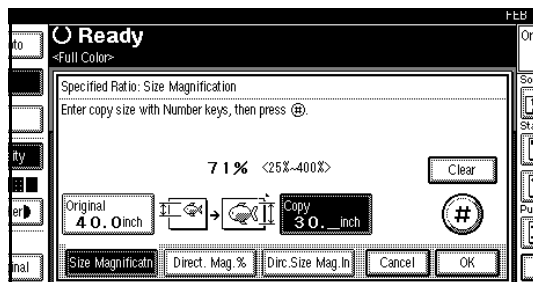

Note

- You can enter sizes within the following ranges:

| | |
|----------------|------------------------------|
| Metric version | 1 – 999mm (in 1mm steps) |
| Inch version | 0.1" – 99.9" (in 0.1" steps) |

- To change the length entered, press [Clear] or the [Clear/Stop] key, and then enter the new length.
- To change the length after pressing [#], select [Original] or [Copy], and then enter the desired length.

6 Press [OK].



- 7** Press [OK].
- 8** Place your originals, and then press the [Start] key.



Directional Magnification (%)

Copies can be reduced or enlarged at different reproduction ratios horizontally and vertically.

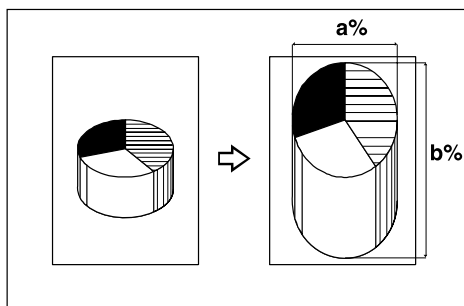

CP2P01EE

Note

- ❑ You can specify the ratio without considering the original and paper size. However, in some occasions, parts of the image might not be copied or margins will appear on copies.
- ❑ You can also select a preset ratio which is close to the desired ratio by using **[Reduce]** or **[Enlarge]**, and then adjust the ratio with **[+]** or **[-]**.

1 Press **[Reduce/Enlarge]**.

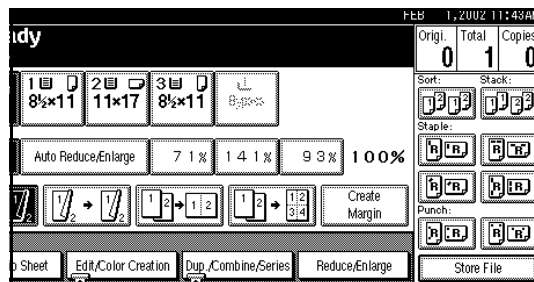

2 Press **[Specify Ratio]**.

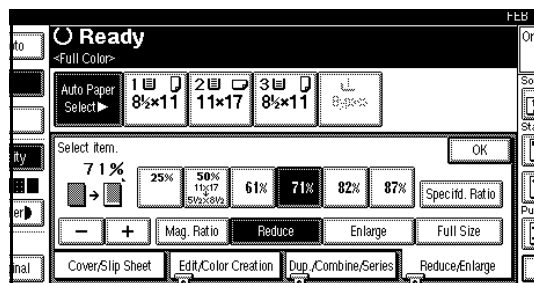



3 Press [Direct. Mag.%].

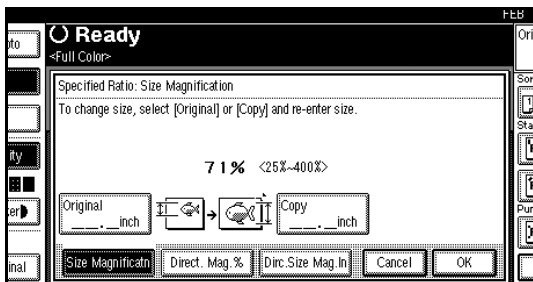

To enter the ratio with the number keys

1 Press [Horizontal].

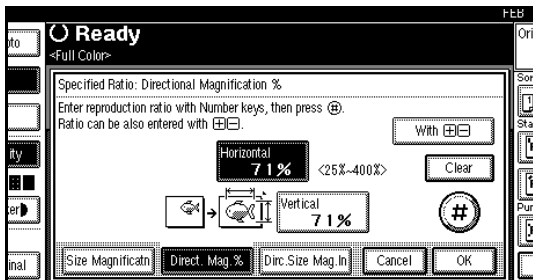

2 Enter the desired ratio with the number keys, and then press [#].

Note

- To change the ratio entered, press [Clear] or the [Clear/Stop] key, and then enter the new ratio.

3 Press [Vertical].

4 Enter the desired ratio with the number keys, and then press [#].

5 Press [OK].

To specify a ratio with [+] and [-]

1 Press [With + -].

2 Press [Horizontal].

3 Adjust the ratio using [+] or [-].

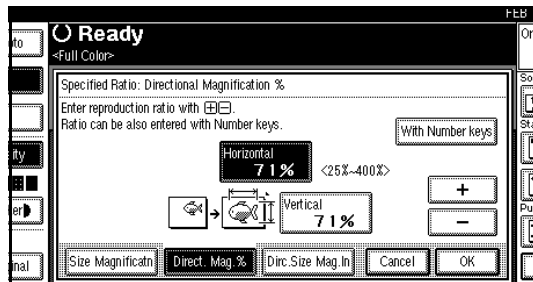



Note

- Pressing **[+]** or **[-]** changes the ratio in 1% steps. Pressing and holding down **[+]** or **[-]** changes it in 10% steps.
- If you have incorrectly entered the ratio, readjust the ratio with **[+]** or **[-]**.

4 Press **[Vertical]**.

5 Adjust the ratio with **[+]** or **[-]**.

6 Press **[OK]**.

4 Press **[OK]**.

5 Place your originals, and then press the **[Start]** key.



Directional Size Magnification (Inch)

The suitable reproduction ratios will be automatically selected when you enter the horizontal and vertical lengths of the original and copy image you require.

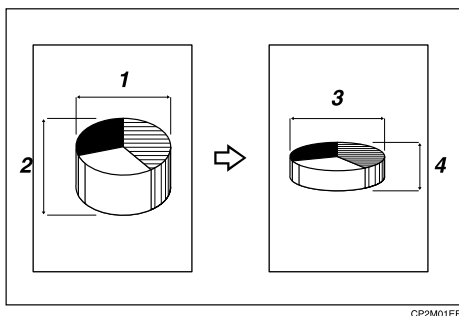

1: Horizontal original size

2: Vertical original size

3: Horizontal copy size

4: Vertical copy size

Preparation

Specify the vertical and horizontal sizes of the original and those of the copy, as shown in the illustration.

Limitation

- If the calculated ratio is over the maximum or under the minimum ratio, it is adjusted to within the available range of ratios automatically. However, with some ratios, parts of the image might not be copied or margins will appear on copies.

Note

- You can enter sizes within the following ranges:

| | |
|----------------|---|
| Metric version | Vertical: 1 – 999mm (in 1mm steps) Horizontal: 1 – 9999mm (in 1mm steps) |
| Inch version | Vertical: 0.1" – 99.9" (in 0.1" steps) Horizontal: 0.1" – 999.9" (in 0.1" steps) |

- The following ratios can be selected:
 - Metric version: 25 – 400%
 - Inch version: 25 – 400%



1 Press [Reduce/Enlarge].

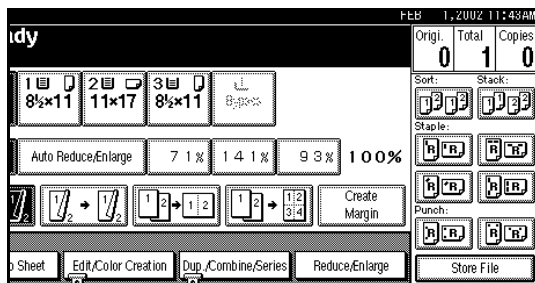

2 Press [Specifd Ratio].

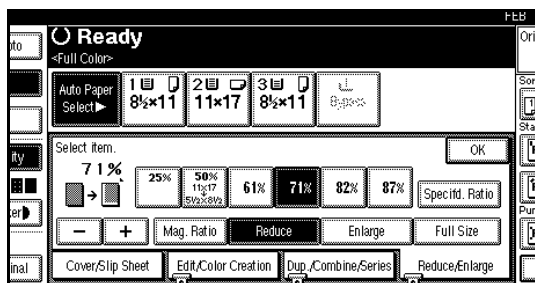

3 Press [Dirc. Size Mag. In].

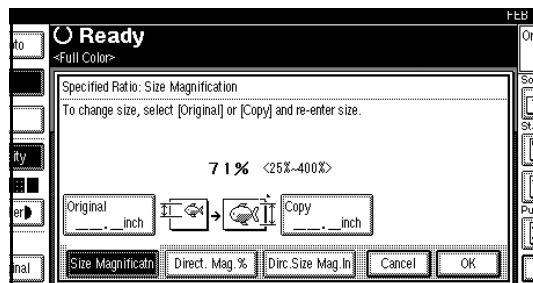

4 Enter the horizontal size of the original with the number keys, and then press [#].

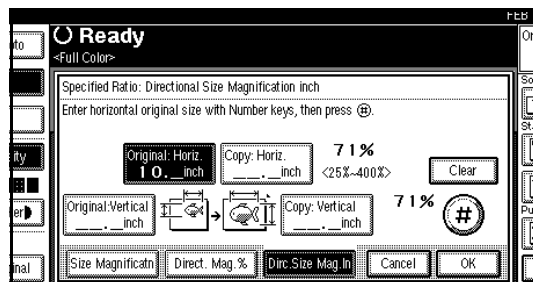

Note

- ❑ The horizontal size you can enter is from 1mm (0.1") to 9999mm (999.9").
- ❑ To change the length entered, press [Clear] or the [Clear/Stop] key, and then enter the new length.



5 Enter the horizontal size of the copy with the number keys, and then press [#].

 **Note**

- The horizontal size you can enter is from 1mm (0.1") to 9999mm (999.9").

6 Enter the vertical size of the original with the number keys, and then press [#].

 **Note**

- The vertical size you can enter is from 1mm (0.1") to 999mm (99.9").

7 Enter the vertical size of the copy with the number keys, and then press [#].

 **Note**

- The vertical size you can enter is from 1mm (0.1") to 999mm (99.9").
- To change a size, press the key you wish to change, and then enter the new length.

8 Press [OK].

9 Press [OK].

10 Place your originals, and then press the [Start] key.





Series

Series copies are made by separately copying the front and back of a 2-sided original or the two facing pages of a spread original onto two sheets of paper.

The following types of Series modes can be used:

❖ Series Copies

- Book → 1 Sided
Copies the two facing pages of a spread original to make two 1-sided copies.

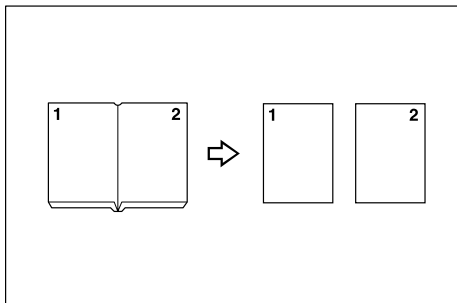

- Book → 2 Sided
The optional duplex unit and hard disk unit (40 GB) are required.
Copies a spread two-page original onto one sheet with one page per side.

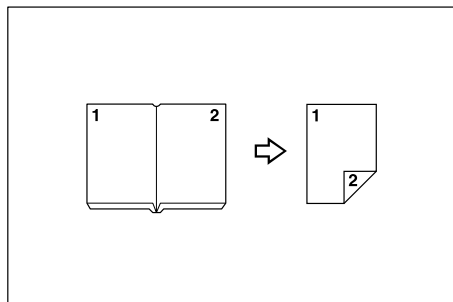



- Front & Back→ 2 Sided
The optional duplex unit and hard disk unit (40 GB) are required.
 Copies each two-page spread original as it is onto both sides of a sheet.

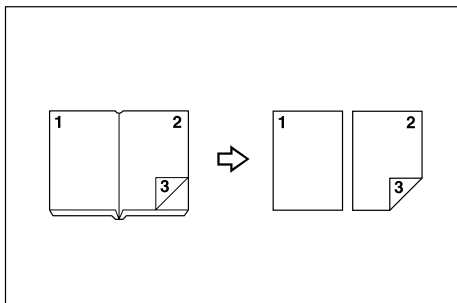

! Limitation

- You cannot use the Series function from the optional document feeder (ADF).

📌 Note

- When you use the “Book → 1 Sided” function, see the following table when you select the original and copy paper sizes with 100% ratio.

❖ Metric version

| Original | Copy paper |
|----------|----------------|
| A3 | A4 × 2 sheets |
| B4 | B5 × 2 sheets |
| A4 | A5 × 2 sheets |

❖ Inch version

| Original | Copy paper |
|-----------|--------------------------|
| 11" × 17" | 8 1/2" × 11" × 2 sheets |

- When you use the “Book→2 Sided” or “Front & Back → 2 Sided” function, see the following table when you select the original and copy paper sizes with 100% ratio.

❖ Metric version

| Original | Copy paper |
|----------|--------------|
| A3 | A4 (2-sided) |
| B4 | B5 (2-sided) |
| A4 | A5 (2-sided) |

❖ Inch version

| Original | Copy paper |
|---|---------------------|
| 11" × 17"  | 8½" × 11" (2-sided) |

1 Press [Dup./Combine/Series].

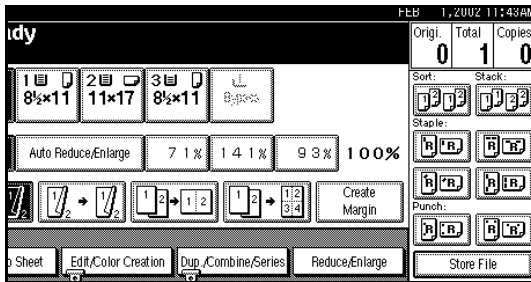

2 Press [Series].

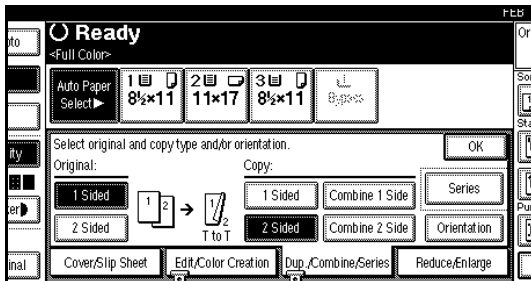

3 Select the Series item, and then press [OK].

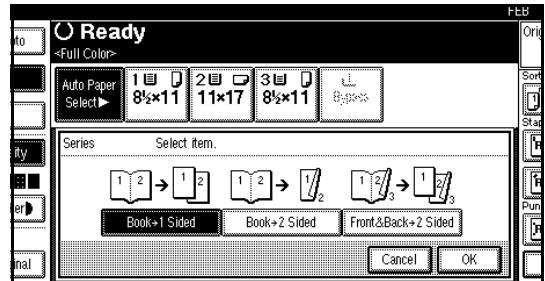

4 Press [OK].

5 Make sure that [Auto Paper Select] is selected.

 **Note**

Press [Auto Paper Select], if not selected.

6 Place your originals, and then press the [Start] key.



Erasing Colors

This function deletes colors in the original and copies it.

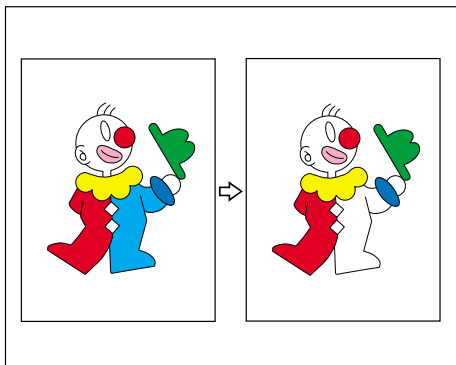

Note

- ❑ It is possible to specify up to 4 colors.
- ❑ The width of the color to be deleted can be adjusted in 5 levels. If the color width is set to “Wide” and red has been specified, colors, which are close to magenta or orange, will be deleted. The color width can be adjusted in the “User Tools”.⇒ [p.127 “Color Sensitivity”](#)

1 Press [Edit/Color Creation].

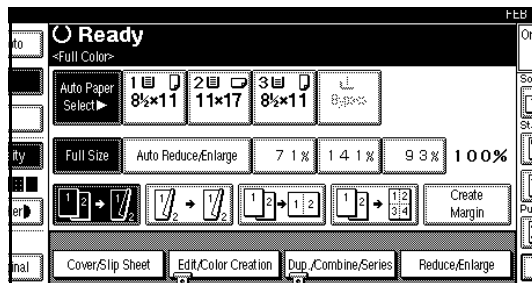

2 Press [Erase Color].

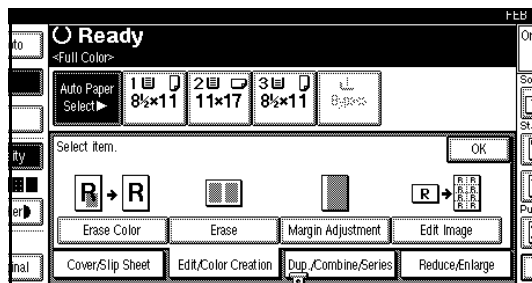



3 Select the color to be deleted.

The key of the selected color will be highlighted.

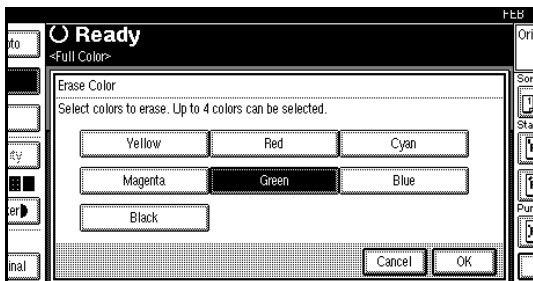

Note

- You can cancel the selection by pressing the selected (highlighted) key.
- You can select up to 4 colors simultaneously.

4 Select the colors you want to delete, and then press [OK].

5 Place your originals, and then press the [Start] key.



Erase

This function erases the center and/or all four sides of the original image. This is useful for avoiding edge margins on the copy image caused by bound originals, such as books.

This function has the following three types:

❖ Border

This mode erases the edge margin of the original image.

❖ Center

This mode erases the center margin of the original image.

❖ Center/Border

This mode erases both the center and edge margins of the original image.

Note

- ❑ The default setting of the erased margin is as follows:

| | |
|----------------|------|
| Metric version | 10mm |
| Inch version | 0.4" |

- ❑ You can change the width of the erased margins as follows:

| | |
|----------------|-----------------------------|
| Metric version | 2 – 99mm (in 1mm steps) |
| Inch version | 0.1" – 3.9" (in 0.1" steps) |











- ❑ You can change this settings with the User Tools.⇒ [p.117 “Erase Border Width”](#), [p.117 “Erase Center Width”](#)
- ❑ The width of the erased margin varies depending on the reproduction ratio.
- ❑ If the size of the original is different from sizes listed in the following chart, the erased margin might be shifted.

❖ Metric version



| Where Original Is Placed | Paper Size and Orientation |
|--------------------------------|---|
| Exposure glass | A3☐, B4☐, A4☐☐, B5☐☐ |
| Optional document feeder (ADF) | A3☐, B4☐, A4☐☐, B5☐☐, A5☐☐, 8½" × 13"☐, 8K☐, 16K☐ |



❖ Inch version

| Where Original Is Placed | Paper Size and Orientation |
|--------------------------------|---|
| Exposure glass | 11" × 17"  , 8½" × 14"  , 8½" × 11"   |
| Optional document feeder (ADF) | A4  , 11" × 17"  , 8½" × 14"  , 8½" × 11"   , US EXE  |

- ❑ The relationship between the original orientation and the erased part is as follows:

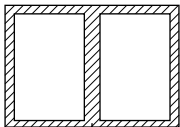
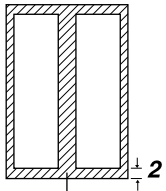
|  original |  original |
|--|--|
|  |  |

- ❑ 1: Erased part
- ❑ 2: 2–99mm (0.1"–3.9")

Border Erase

This function erases the edge margins. You can set the same margin width for all four sides, or you can set different margin widths for each side.

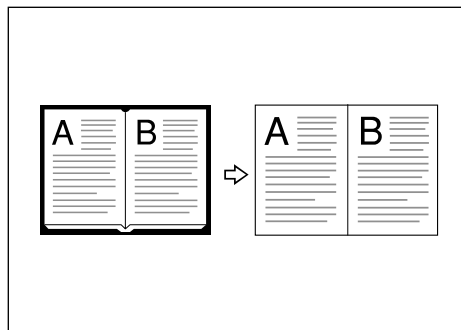

GCCENT2E

Note

- ❑ If you want to erase the center margin too, use the Center/Border Erase function. ⇒ [p.29 "Center/Border Erase"](#)



1 Press [Edit/Color Creation].

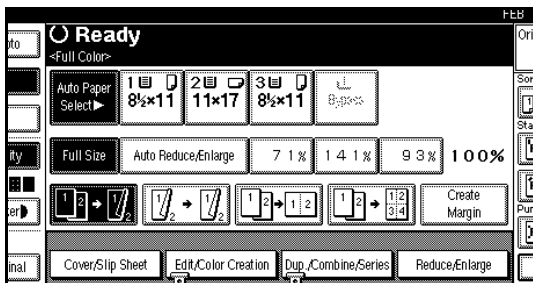

2 Press [Erase].

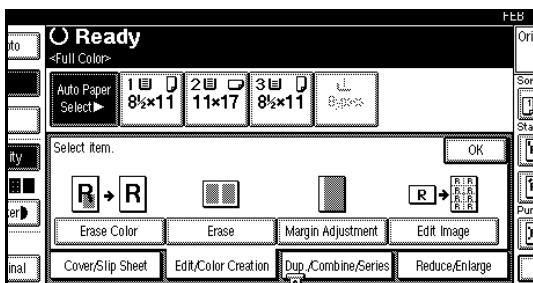

3 Press [Border].

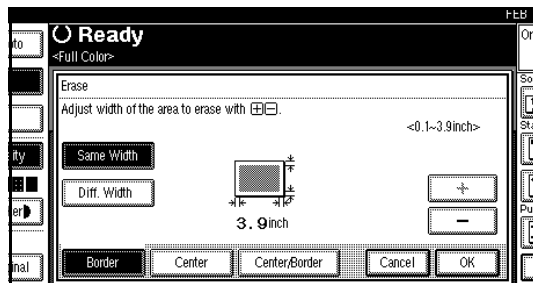

4 Specify the erase border width with [+] and [-], and then press [OK].

5 Press [OK].

6 Place your originals, and then press the [Start] key.



Center Erase

This function erases the center margin.

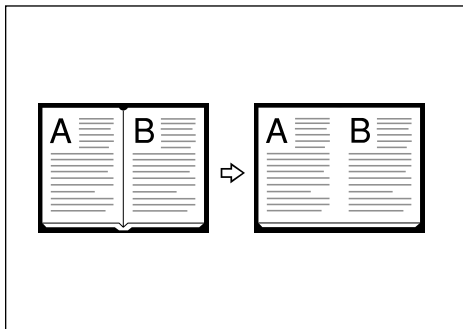

GCCE11E

Note

- If you want to erase the border margin too, use the Center/Border Erase function. ⇒ p.29 “Center/Border Erase”

1 Press [Edit/Color Creation].

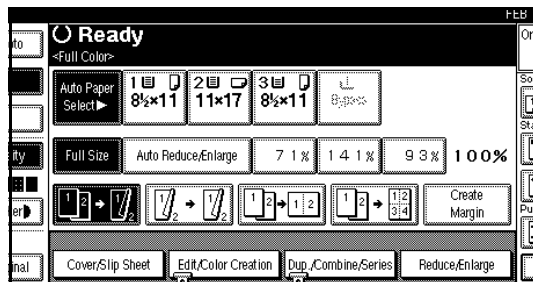

2 Press [Erase].

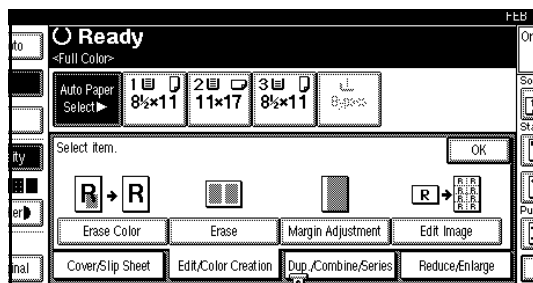

3 Press [Center].

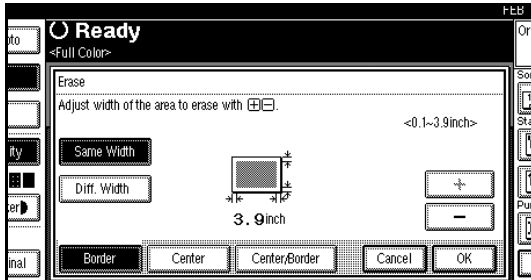

4 Specify the erase center width with [+] and [-], and then press [OK].

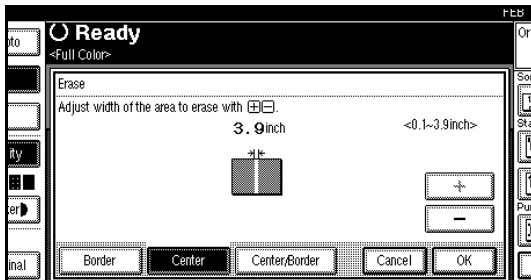

Note

- To change the width entered, press [+] and [-], and then enter the new width.

5 Press [OK].

6 Place your originals, and then press the [Start] key.

Center/Border Erase

This mode erases both the center and edge margins. You can set the same margin width for all four sides and the center, or you can set different margin widths for each.

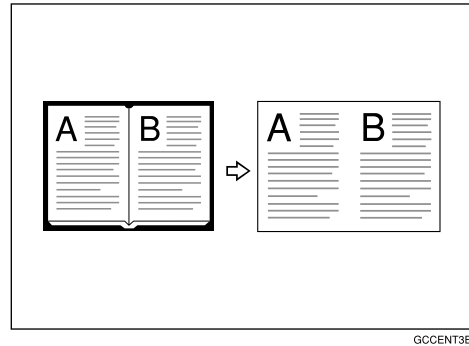

1 Press [Edit/Color Creation].

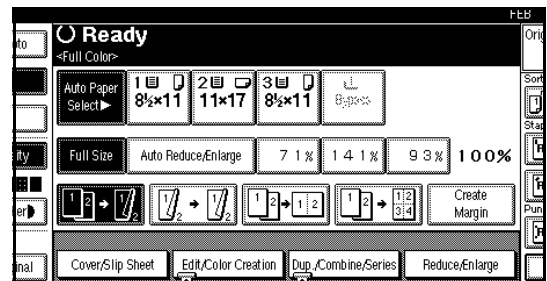

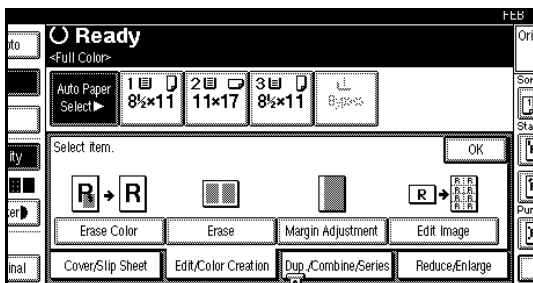
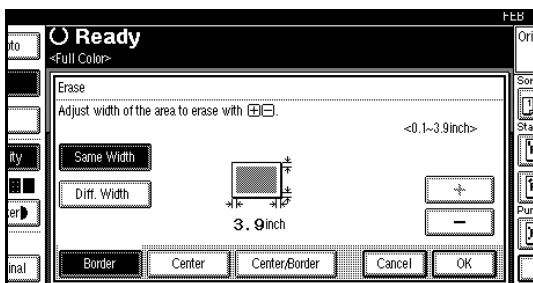
**2** Press [Erase].**3** Press [Center/Border].**4** Specify the erase margin width.

Selecting [Same Width]

- 1 Press [Center], and then specify the erase center width with [+] and [-].

Note

- To change the width entered, press [+] and [-], and then enter the new width.

- 2 Press [Same Width].

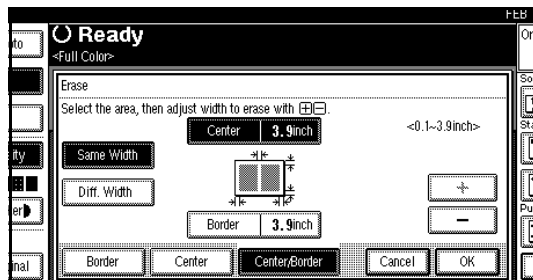

- 3 Press [Border], and then specify the erase border width with [+] and [-].

Note

- To change the width entered, press [+] and [-], and then enter the new width.

- 4 Press [OK].

Selecting [Diff. Width]

- 1 Press [Diff. Width].
- 2 Press the key for the part you wish to change, and then specify an erase margin width with [+] and [-].

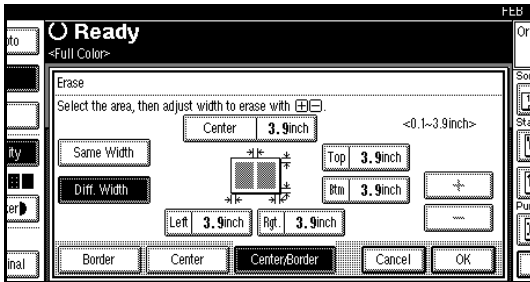

Note

- To change the width entered, press [+] and [-], and then enter the new width.

- 3 Press [OK].
- 5 Press [OK].
- 6 Place your originals, and then press the [Start] key.



Margin Adjustment

You can shift the image to the left, right, top or bottom to make a binding margin.

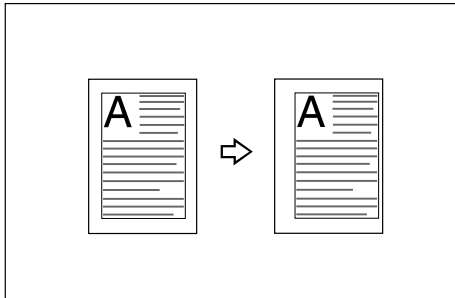

! Limitation

- ❑ If you set the margin too wide, areas you do not want to delete might be erased.

📌 Note

- ❑ You can change the margin adjustment setting with the User Tools. ⇒ p.115 “Front Margin: Left/Right”, p.115 “Back Margin: Left/Right”, p.115 “Front Margin: Top/Bottom”, p.116 “Back Margin: Top/Bottom”

- ❑ When making 2 Sided copies from 1 Sided originals, you can set a binding margin for back side pages. ⇒ p.116 “1 sided→2 sided Auto Margin:T to T”, p.116 “1 Sided→2 Sided Auto Margin: TtoB”
- ❑ When making copies in Combine mode, the binding margins are made on the copies after the combining is finished.
- ❑ When making copies in Double Copies or Image Repeat, the margins will appear on the copies.
- ❑ When “2 Sided → 1 Sided” is selected, set the binding margins for front and back pages of the original.
- ❑ You can change the width of the binding margin as follows:

| | |
|----------------|---------------------------|
| Metric version | 0 – 30mm (in 1mm steps) |
| Inch version | 0" – 1.2" (in 0.1" steps) |

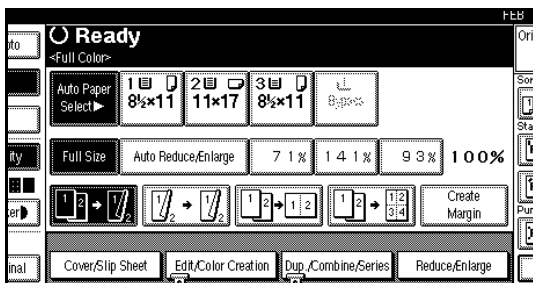
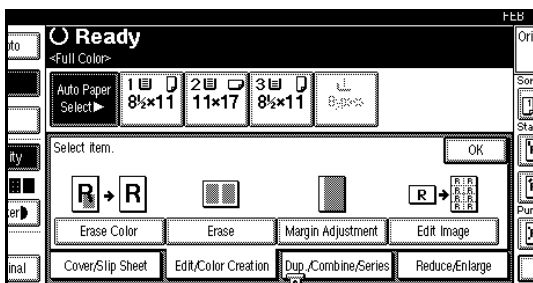
**1** Press [Edit/Color Creation].**2** Press [Margin Adjustment].**3** Set a binding margin for a front page.

Press [←] and [→] when setting the left and right margins, and [↑] and [↓] when setting the top and bottom margins.

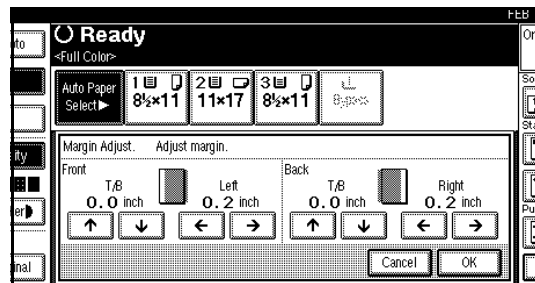
**Note**

- The binding margin width you can enter is from 0 to 30mm (0" to 1.2").
- To change the width entered, press [←], [→], [↑], [↓], and then enter the new width.



4 Set a binding margin for a back side page.

Press [←] and [→] when setting the left and right margins, and [↑] and [↓] when setting the top and bottom margins.

 **Note**

- The binding margin width you can enter is from 0 to 30mm (0" to 1.2").
- You can specify the back side margin only when Duplex or 2 Sided copy with Combine is selected.
- If you do not need to specify the back margin, press [OK] and go to step **5**.

5 Press [OK].

6 Place your originals, and then press the [Start] key.





Image Repeat

The original image is copied repeatedly.

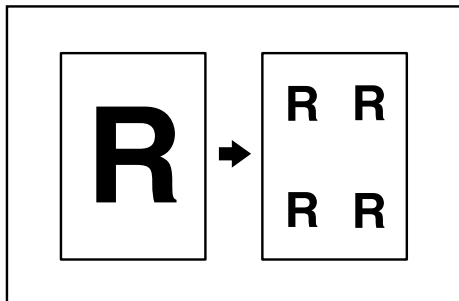

The way of specifying Image Repeat is as follows:

❖ Whole Area Repeat

Re-copies the entire image.

❖ Specified Area Repeat

Re-copies an image in a specified area. First, choose the starting point of the area; next choose the location of the area by specifying the length and width.

Note

- The number of copies, which can be repeated on a single sheet of paper, is set automatically, depending on the size of the original, the paper size, and the reproduction ratio.
- You can insert separation lines between repeated images.⇒ [p.119 “Image Repeat Separation Line”](#)
- Part of a repeated image might not be copied depending on copy paper size, copy paper direction, type of separation lines or reproduction ratio.

Whole Area Repeat

- 1 Select the size of the copy paper and the reproduction ratio.
- 2 Press [Edit/Color Creation].

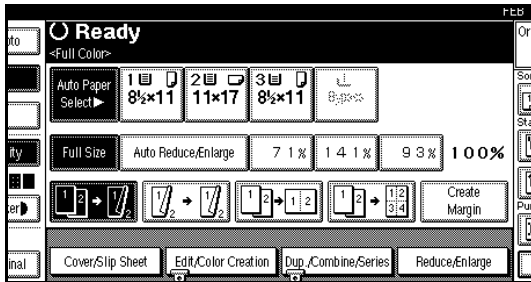

- 3 Press [Edit Image].

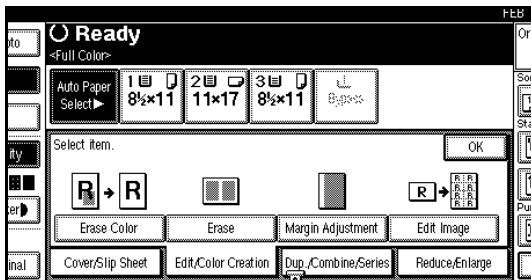

- 4 Press [Image Repeat].

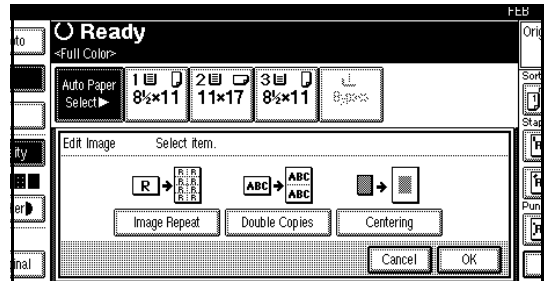

- 5 Make sure that [Whole Area] is selected, and then press [OK].

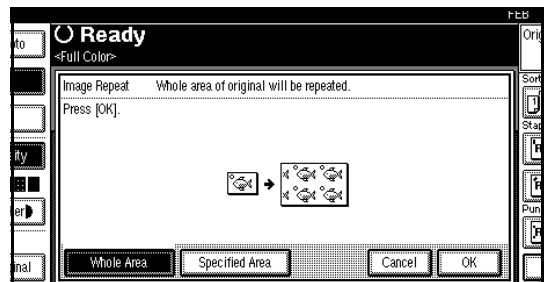

- 6 Press [OK].
- 7 Press [OK].
- 8 Place your originals, and then press the [Start] key.

Specified Area Repeat

Limitation

- Place your originals on the exposure glass when using the Specified Area Repeat function.

1 Choose the position of the starting point of the area (X1, Y1), and the length and width of the area (X2, Y2).

Note

- You can set the area in the following ranges:

| | |
|----------------|--|
| Metric version | X1 = 0 to 412mm, X2 = 20 to 432mm, Y1 = 0 to 277mm, Y2 = 20 to 297mm |
| Inch version | X1 = 0.0" to 16.2", X2 = 0.8" to 17", Y1 = 0.0" to 10.8", Y2 = 0.8" to 11.6" |

2 Select the reproduction ratio and the paper size.

3 Press [Edit/Color Creation].

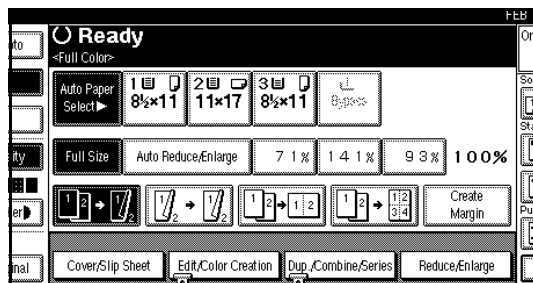

4 Press [Edit Image].

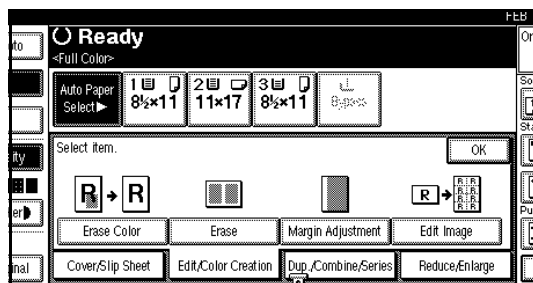

5 Press [Image Repeat].

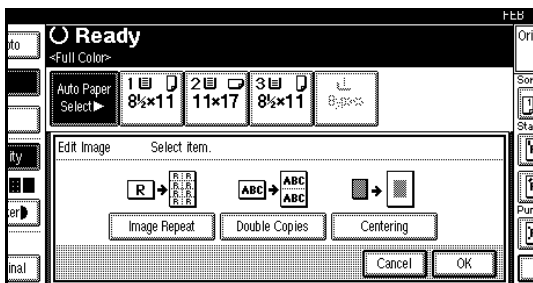

6 Press [Specified Area].

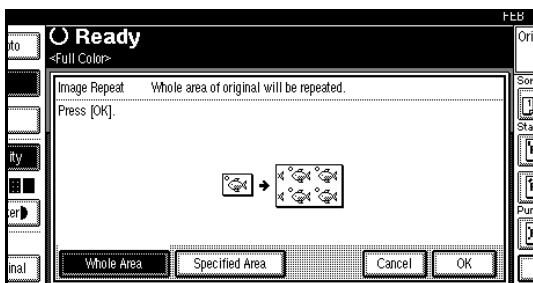

7 Enter the length of [X1] using the number keys, and then press [#].

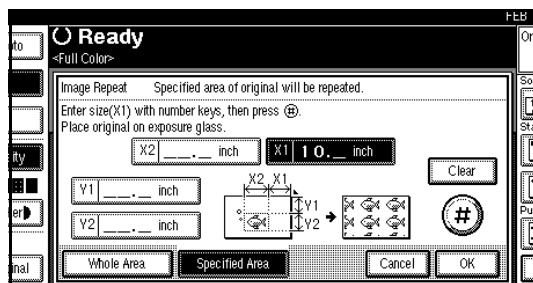

Note

- To change the length entered, press [Clear] or the [Clear/Stop] key, and then enter the number.

8 Enter the length of [Y1] using the number keys, and then press [#].

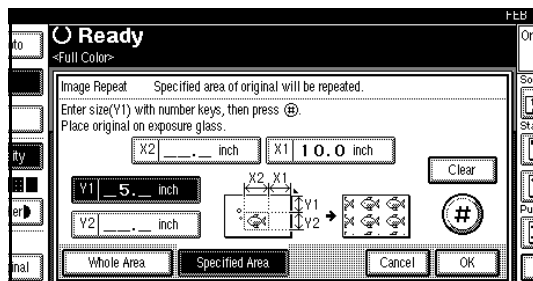

- 9** Enter the length of [X2] using the number keys, and then press [#].

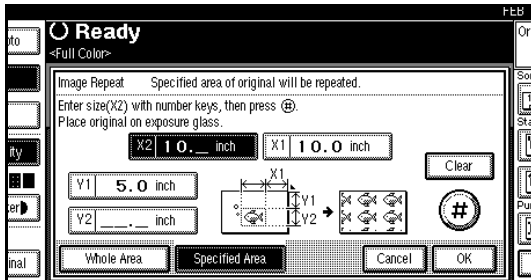

- 14** Place your originals on the exposure glass, and then press the [Start] key.

- 10** Enter the length of [Y2] using the number keys, and then press [#].

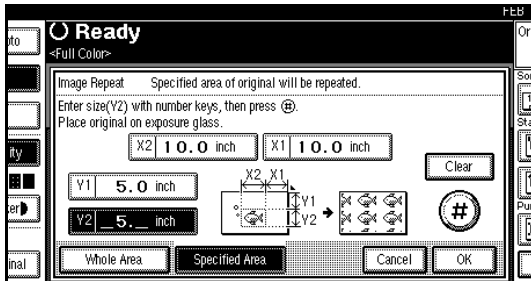

- 11** Press [OK].

- 12** Press [OK].

- 13** Press [OK].





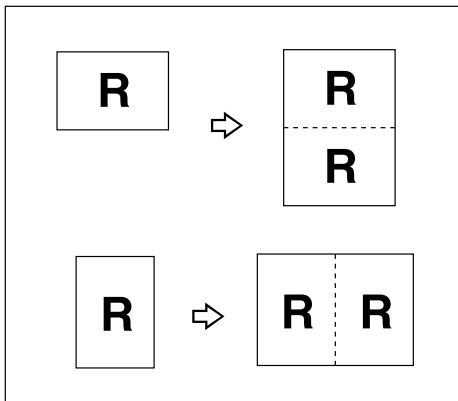

Double Copies

One original image is copied twice on one copy as shown in the illustration.



Limitation

- ❑ The following originals cannot be detected properly on the exposure glass. Be sure to select the copy paper manually or place the originals in the optional document feeder (ADF).







| | |
|----------------|---|
| Metric version | A5  , B6  |
| Inch version | 5 1/2" × 8 1/2"   |

- ❑ You cannot use the Bypass Tray with this function.







Note

- ❑ You can insert separation lines between repeated images. → p.121 “Double Copies Separation Line”
- ❑ See the following table for original and copy paper sizes when using a 100% ratio.

❖ Metric version

| Original Size and Direction | Copy Paper Size and Direction |
|--|--|
| A5  | A4  |
| A4  | A3  |
| A5  | A4  |

❖ Inch version

| Original Size and Direction | Copy Paper Size and Direction |
|---|--|
| 5 1/2" × 8 1/2"  | 8 1/2" × 11"  |
| 5 1/2" × 8 1/2"  | 8 1/2" × 11"  |
| 8 1/2" × 11"  | 11" × 17"  |



- 1 Press [Edit/Color Creation].

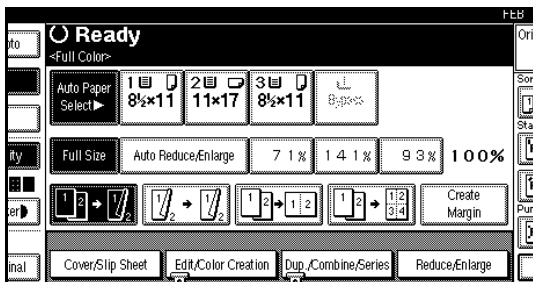

- 2 Press [Edit Image].

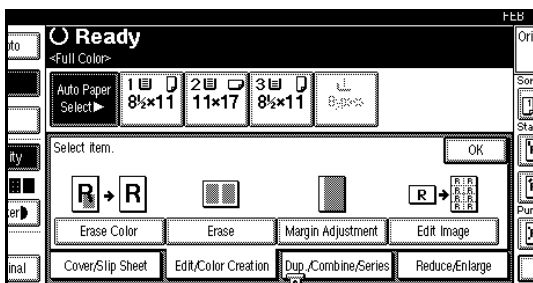

- 3 Press [Double Copies].

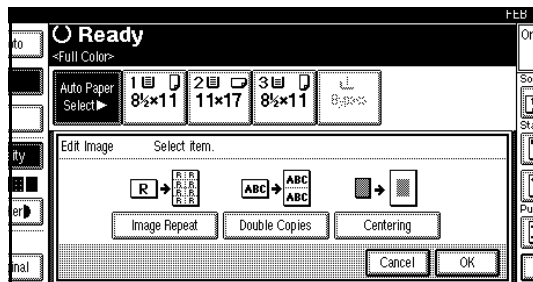

- 4 Press [OK].

- 5 Press [OK].

- 6 Select the paper.

- 7 Place your originals, and then press the [Start] key.



Centering

You can make copies with the image moved to the center of the copy paper.

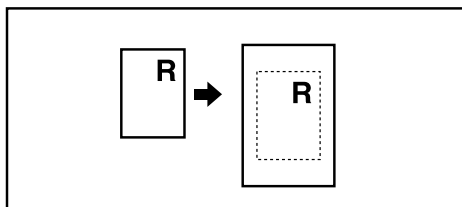

















Limitation

- You cannot use the Bypass Tray with this function.
- If the direction of originals is different from that of the copy paper, the machine will not rotate the image 90° (Rotated Copy). However, you can rotate the image 90 degrees when using this function with “Auto Reduce/Enlarge”.
- If the original size cannot be detected, the centering function will not work.
- The combined areas will be centered when using the Combine function.











Note

- The original sizes and directions for centering are listed below:

❖ Metric version

| Where Original is Placed | Paper Size and Orientation |
|--------------------------------|--|
| Exposure glass | A3  , B4  , A4   , B5   |
| Optional document feeder (ADF) | A3  , B4  , A4   , B5   , A5   , 8 1/2" × 13"  , 8K  , 16K  |

❖ Inch version

| Where Original is Placed | Paper Size and Orientation |
|--------------------------------|--|
| Exposure glass | 11" × 17"  , 8 1/2" × 14"  , 8 1/2" × 11"   |
| Optional document feeder (ADF) | A4  , 11" × 17"  , 8 1/2" × 14"  , 8 1/2" × 11"   , US EXE  |



1 Select the paper.

2 Press [Edit/Color Creation].

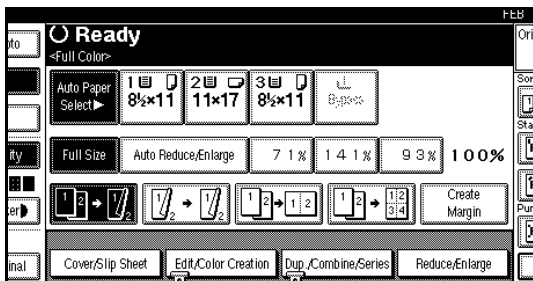

3 Press [Edit Image].

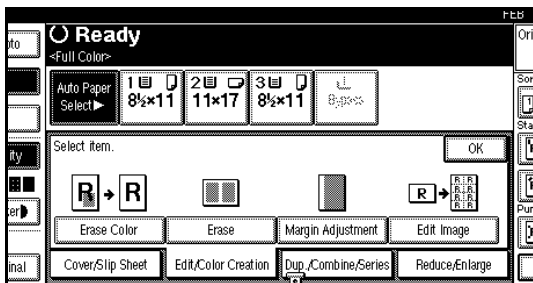

4 Press [Centering].

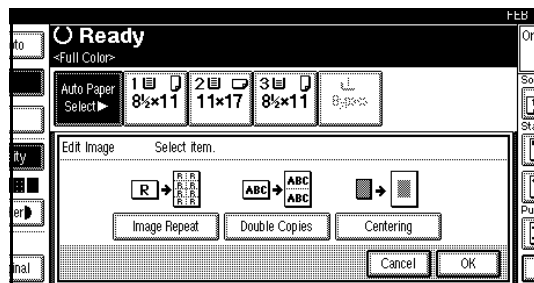

 **Note**

- If you want to cancel centering, press [Cancel].

5 Press [OK].

6 Press [OK].

7 Place your originals, and then press the [Start] key.



Cover

Using this function, you can add cover sheets.

The types of this function are as follows:

❖ Front Cover

The first page of your originals is copied on a specific paper sheet for covers.

❖ Front/Back Covers

The first and last pages of your originals are copied on specific paper sheets for covers.

📌 Limitation

- You cannot specify the Bypass Tray as the paper tray.

📄 Preparation

Before selecting this function, set the tray for front cover paper. ⇒ “Cover Sheet Tray (for Copy/Document Server function only)”, Administrator Reference 2 Copier System Edition

The cover paper should be the same size and orientation as the copy paper.

📌 Note

- If “Blank” mode is selected, the cover will not be counted as a copy.

Front Cover

The first page of your originals is copied on a specific paper sheet for covers, or a cover sheet is inserted before the first copy.

❖ Copy

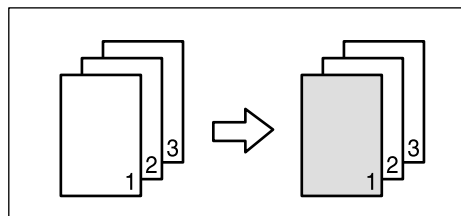

❖ Blank

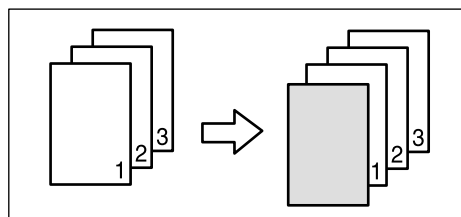



Note

- ❑ You can specify whether to make a copy on the cover sheet. If you select **[Copy]**, the first page will be copied on the cover sheet. If you select **[Blank]**, a cover sheet will just be inserted before the first copy.
- ❑ When choosing **[Copy]**, select whether the front and back covers are copied single-sided (“1 Sided Only”) or double-sided (“Duplex Copy”). ⇒ “Cover Sheet Tray (for Copy/Document Server function only)”, Administrator Reference 2 Copier System Edition
- ❑ When the Duplex mode is selected, the machine refers to the setting used in the selected mode in “Tray Display” of the User Tools (System Settings).
 - “Mode Selected”: the machine refers to the settings in “Cover”.
 - “Display Always”: the machine refers to the settings in “Special Paper Indication”. ⇒ “Paper Type (Tray 1 - 4)” and “Cover Sheet Tray (for Copy/Document Server function only)”, Administrator Reference 2 Copier System Edition
- ❑ When you use this function with Combine mode, you can specify whether to combine the front cover or not. ⇒ p.118 “Front Cover Copy in Combine”

1 Press **[Cover/Slip Sheet]**.

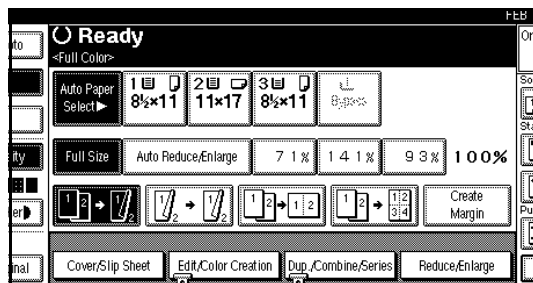

2 Press **[Front Cover]**.

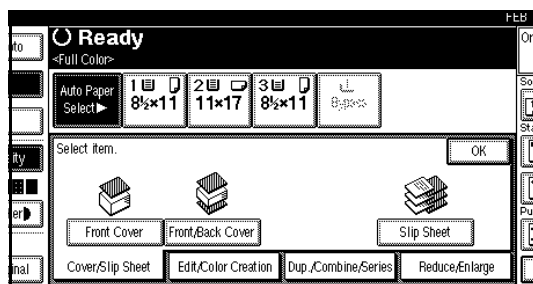



- 3** Select [Copy] or [Blank] for the cover sheet.

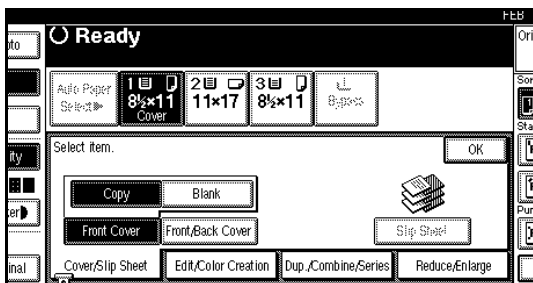

- 4** Select the paper tray containing the non-cover sheet paper.

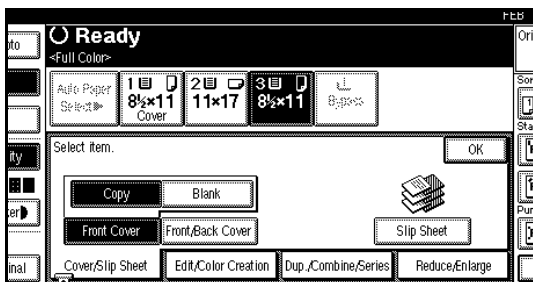

- 5** Place your originals, and then press the [Start] key.

 **Note**

- Press the [#] key after the last original has been scanned, when placing originals on the exposure glass.

Front/Back Covers

The first and last pages of your originals are copied on specific paper sheets for covers.

◆ Copy

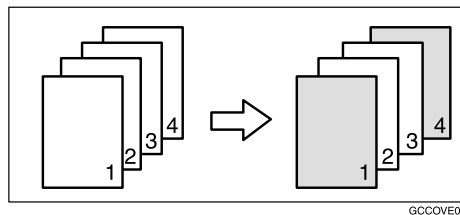

◆ Blank

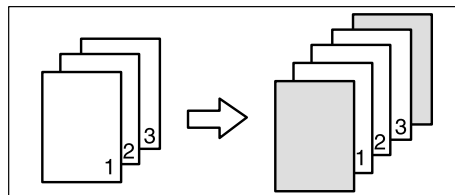

Note

- You can specify whether to make a copy on a cover sheet. If you select **[Copy]**, the first and last pages will be copied on the cover sheets. If you select **[Blank]**, a cover sheet will just be inserted before the first copy and another sheet after the last copy.
- When choosing **[Copy]**, select whether the front and back covers are copied single-sided (“1 Sided Only”) or double-sided (“Duplex Copy”). ⇒ “Cover Sheet Tray (for Copy/Document Server function only)”, Administrator Reference 2 Copier System Edition
- When the Duplex mode is selected, the machine refers to the setting used in the selected mode in “Tray Display” of the User Tools (System Settings).
 - “Mode Selected”: the machine refers to the settings in “Cover”.
 - “Display Always”: the machine refers to the settings in “Special Paper Indication”. ⇒ “Paper Type (Tray 1 - 4)” and “Cover Sheet Tray (for Copy/Document Server function only)”, Administrator Reference 2 Copier System Edition

1 Press **[Cover/Slip Sheet]**.

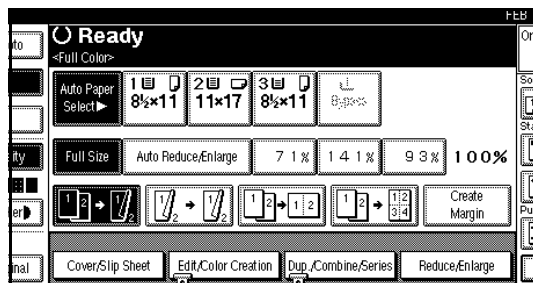

2 Press **[Front/Back Cover]**.

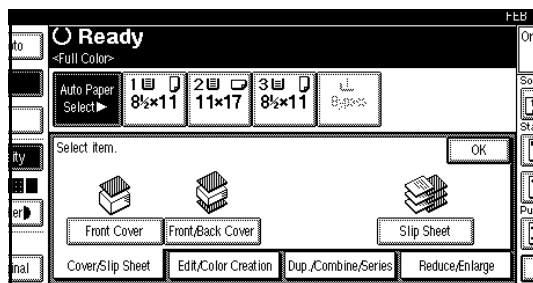



3 Select [Copy] or [Blank] for the cover sheets.

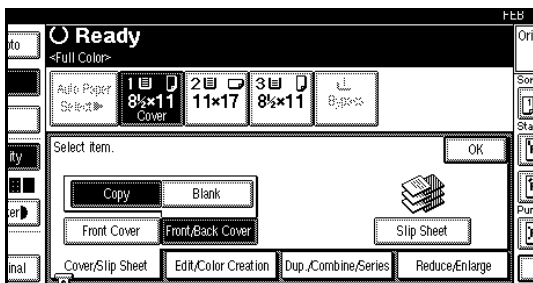

4 Select the paper tray containing the non-cover sheet paper.

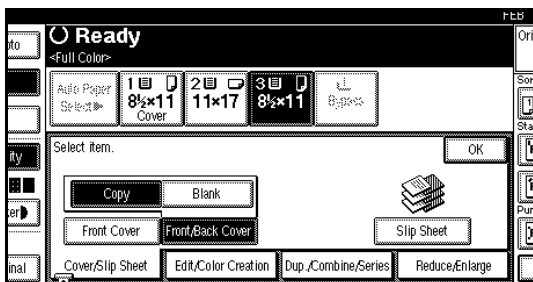

5 Place your originals, and then press the [Start] key.

 **Note**

- Press the [#] key after the last original has been scanned, when placing originals on the exposure glass.



Slip Sheets

Every time the originals' page changes, a slip sheet is inserted. This function can be used to insert a slip sheet automatically between each OHP transparency copied or used as a Stack function. You can also copy onto the inserted slip sheets.

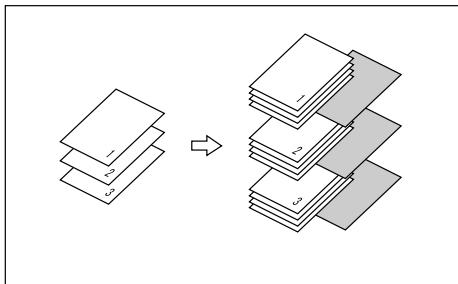

Limitation

- You cannot specify the Bypass Tray as the paper tray for the slip sheets.

Preparation

Before selecting this function, specify the paper tray for slip sheets. ⇒ “Slip Sheet Tray (for Copy/Document Server function only)”, Administrator Reference 2 Copier System Edition

The default setting of inch version is “1 Sided → 2 Sided”. When copying with the Slip Sheets function, set “1 Sided → 1 Sided” in “Dup./Combine/Series”.

Note

- The paper tray specified for “Slip Sheet” is used in this function.
- Set the slip sheets in the same orientation as originals.
- You can specify whether to copy onto the inserted slip sheets or not.
- If you do not copy onto slip sheets, they are excluded from the number of copies counted.

When inserting slip sheets between OHP transparencies

- Copy

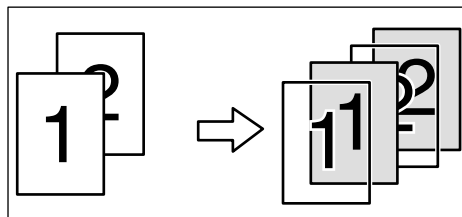

- Blank

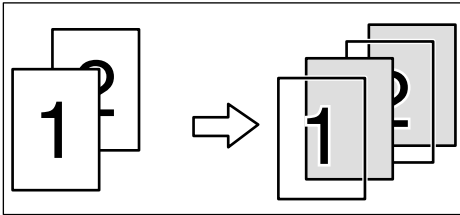

Note

- When placing OHP transparencies in the Bypass Tray, press the [#] key, and then select [OHP Sheet] in Special Paper. ⇒ “When Copying onto OHP Transparencies or Thick Paper”, *Basic Features* manual
- You cannot specify anything but “1” for the copy amount, when inserting slip sheets between OHP transparencies.

1 Press [Cover/Slip Sheet].

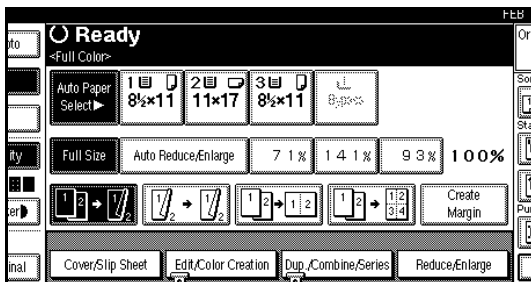

2 Press [Slip Sheet].

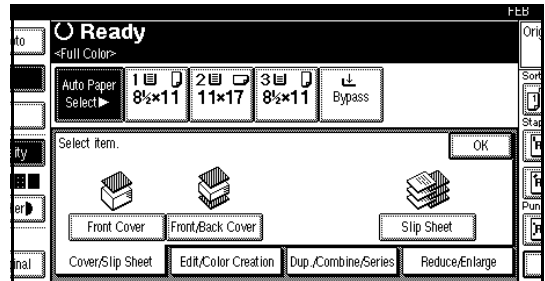

3 Select [Copy] or [Blank] for a slip sheet.

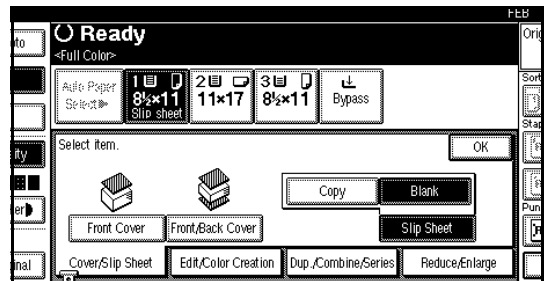

4 Press [OK].

5 Select the paper tray containing the non-slip sheet paper.

When using OHP transparencies, open the Bypass Tray.

6 Place your originals, and then press the [Start] key.



Storing the File in the Document Server

The optional hard disk unit (40 GB) is required.

The Document Server enables you to save documents in the hard disk unit (40 GB), and then print them as you want.

Reference

⇒ “Document Server”, Administrator Reference 2 Copier System Edition

Note

- It may not be possible to change the file name or the user name of a stored document a while after it has been stored.
- The start of a scanning operation and the start timing of an indicator may actually be different when trying to perform the scanning of a color original when color printing.

1 Press [Store File].

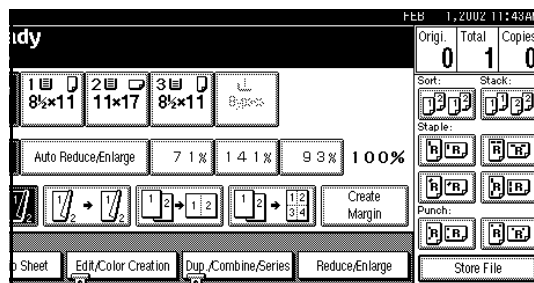

2 Enter a file name, user name, or password if necessary.

Note

- Proceed to step **3** if the user name, file name or password have not been set.

- ❑ If the file name has not been entered, an automatically given file name will be set.

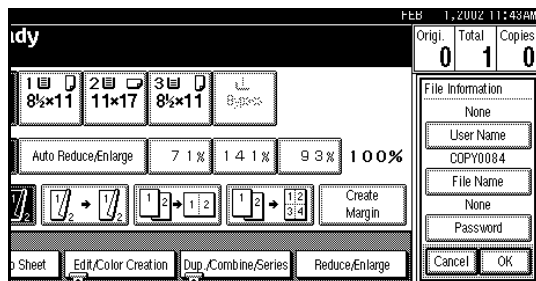

Reference

For information regarding the password settings ⇒ “To set or change the password”, Administrator Reference 2 Copier System Edition

3 Press [OK].

4 Place your originals.

Reference

For more information on the types of originals that can be placed and how to place them, see “Placing the Original”, *Basic Features* manual.

5 Make the scanning settings for the original.

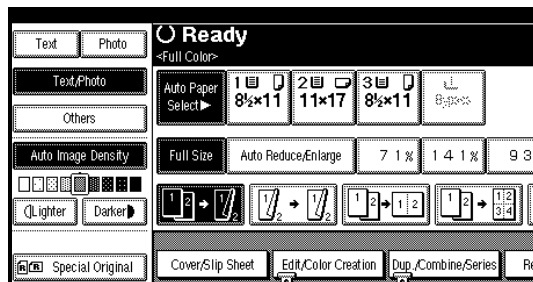

Reference

For details, see the explanations of each function in this manual.

6 Press the [Start] key.

The original is scanned.

Note

- ❑ To stop scanning, press the **[Clear/Stop]** key.
- ❑ To continue a paused scanning job, press **[Continue]** in the confirmation dialog box. To delete the saved images and cancel the job, press **[Stop]**.
- ❑ To check if the document has been stored, press the **[Document Server]** key to display the document selection screen.
- ❑ Documents stored in the Document Server can be set to be deleted automatically after a set number of days. The factory default settings are set to delete after “One day”.



Programs

You can store frequently used copy job settings in machine memory and recall them for future use.

❖ Storing a Program

You can store the settings you frequently use.

❖ Deleting a Program

You can delete a stored program.

❖ Recalling a Program

You can recall a stored program.

❖ Changing a Program's Name

You can change a program's name.

Note

- You can store up to 10 programs.
- You can select the standard mode or program No. 10 as the mode to be set when modes are cleared or reset, or immediately after the operation switch is turned on.⇒ p.107 “Change Initial Mode”

- Paper settings are stored based on paper size. So if you place more than one paper tray of the same size, the paper tray prioritized with the User Tools (System Settings) will be selected first. ⇒ “Paper Tray Priority : Copier (for Copy/Document Server function only)”, Administrator Reference 2 Copier System Edition
- Programs are not cleared by turning the power off or by pressing the **【Clear Modes】** key. They are canceled only when you delete or overwrite them with another program.



Storing a Program

1 Edit the copy settings so that all functions you want to store in this program are selected.

2 Press the **[Program]** key.

The Program menu appears.

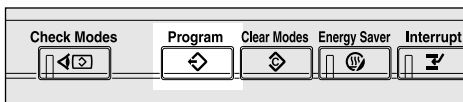

ZFNS013N

3 Press **[Register]**.

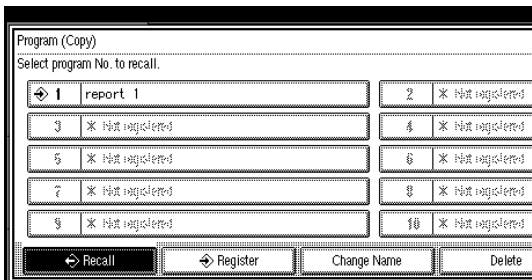

4 Press the program number you want to store.

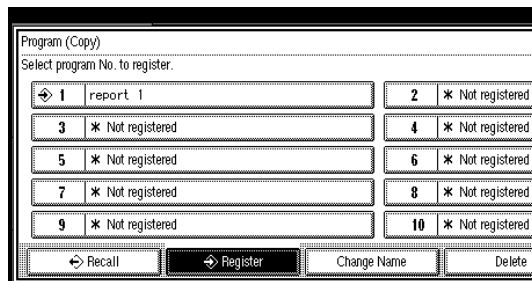

Note

□ Program numbers with already have settings in them.

Reference

⇒ p.55 “Changing a Stored Program”



- 5** Enter the program name with the letter keys on the display panel.

You can enter up to 40 characters.

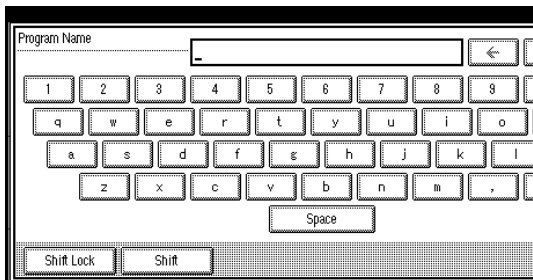

Reference

For details on entering characters, see “Entering Text”, Administrator Reference 2 Copier System Edition.

Note

- If you do not wish to enter the program name, go to step **6**.

- 6** Press [OK].

When the settings are successfully stored, the  indicator goes on.

The screen returns to the initial copy display after a while.

Changing a Stored Program

- 1** Make sure the program settings.

Note

- When you want to check the contents of a program, recall the program. ⇒ p.57 “Recalling a Program”

- 2** Repeat steps **1** to **4** in “Storing a Program” (⇒ p.54).

A confirmation message appears.

To overwrite the program

Important

- If you overwrite the program, the previous program is deleted.



1 Press [Register].

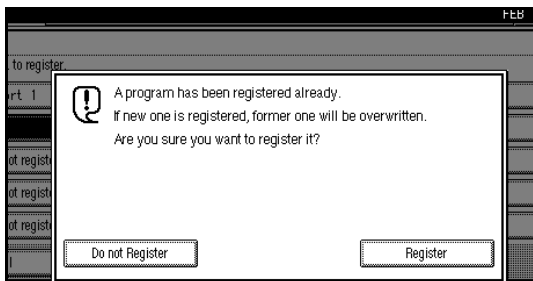

2 Repeat steps 5 and 6 in “Storing a Program” (⇒ p.54).

Not to overwrite the program

1 Press [Do not Register].

The screen returns to the initial Program menu.

Deleting a Program

1 Press the [Program] key.

The Program menu appears.

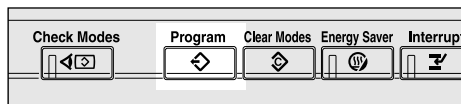

ZFNS013N

2 Press [Delete].

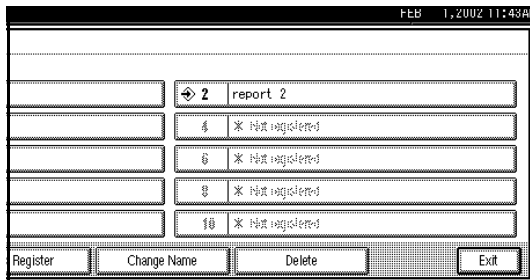



- 3 Press the program number you want to delete.

A confirmation message appears.

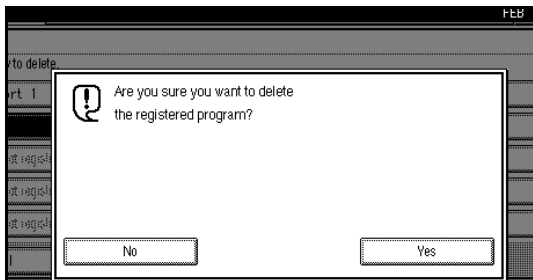

- 4 Press [Yes].

The program is deleted, and the screen returns to the initial copy display.

 **Note**

- To cancel the operation, press [No].

Recalling a Program

- 1 Press the [Program] key.

The Program menu appears.

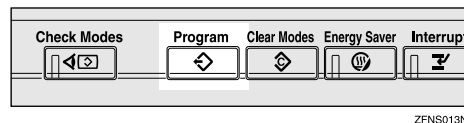

- 2 Press the program number you want to recall.

The stored settings are displayed.

 **Note**

- Only programs with  contain a program.

- 3 Place your originals, and then press the [Start] key.



Changing a Program's Name

- 1 Press the **[Program]** key.

The Program menu appears.

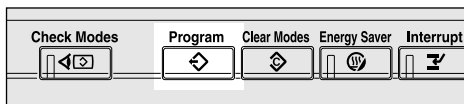

- 2 Press **[Change Name]**.

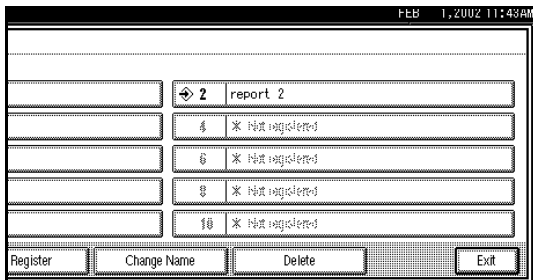

- 3 Press the program number you want to change.

- 4 Change the program's name.

You can enter up to 40 characters.

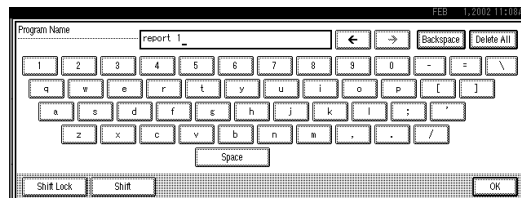

Reference

For details on entering characters, see "Entering Text", Administrator Reference 2 Copier System Edition.

- 5 Press **[OK]**.

The screen returns to the initial Program menu.

The changed program name will appear.

The screen returns to the initial copy display after a while.



User Color

You can register colors made by adjusting the density of yellow, magenta, cyan, and black. The following shows you how to create colors:



- Adjusting the density of each color, by using the density of a chosen basic color.
- Directly specifying the density of each color using the number keys.

Limitation

- ❑ Adjust the colors so that the total of yellow, magenta, cyan and black is under 255%.
- ❑ When the total density of a registered color is over 256%, it will be corrected to 255%.

Note

- ❑ When copying using user colors, the fine shades might vary depending on the condition of the machine.
- ❑ In order to correctly reproduce originals, the values, which have been entered, are corrected inside the machine, and copies are made using the best suitable values. Therefore, there might be slight color differences when copying using “Text” and when using “Photo”.
- ❑ Up to 15 colors can be registered.

- ❑ Sample prints of user colors can also be made on an A4  size page or on an A3  size page.
- ❑ When printing a Sample of User Color, the full color counter will advance to 1.

1 Press the **[Adjust/Program Color]** key.

The **Adjust/Program Color** indicator lights up.

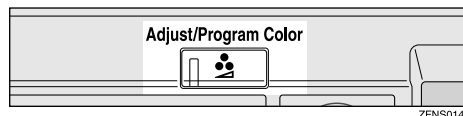

2 Press **[User Color]**.

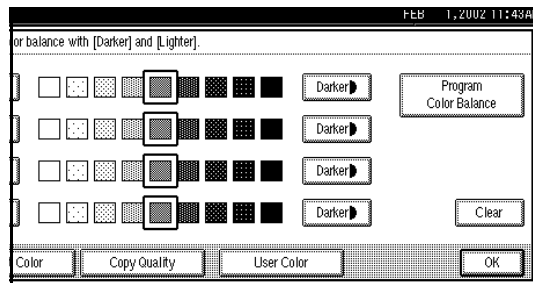

3 Make sure that **[Program]** is selected.



- 4** Select the number ([1*Not programed] to [15*Not programed]) you want to store the user color in .

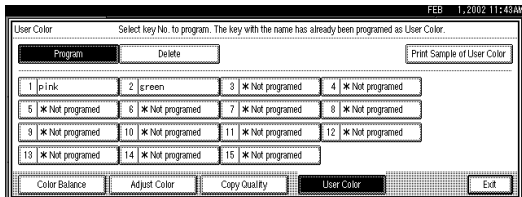

Note

- The contents of the user color will change when selecting the number already displayed by the color name.

- 5** Select the color to be used as a base for registration.

The density of each color for the selected color is displayed.

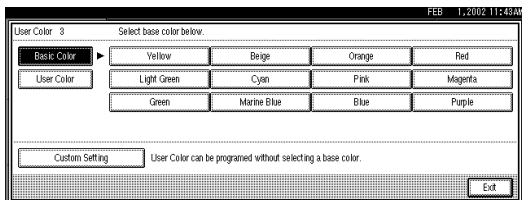

Note

- Press [With Number Keys] if you are directly specifying the density of each color with the number keys. ⇒ p.62 "Mixing Colors Manually with the Number Keys"
- If you select [User Color] you can choose a color from the User Colors.

- 6** Specify the color density.

Using [+], [-]

- 1** Specify the density in percentages (%) using [+], [-].

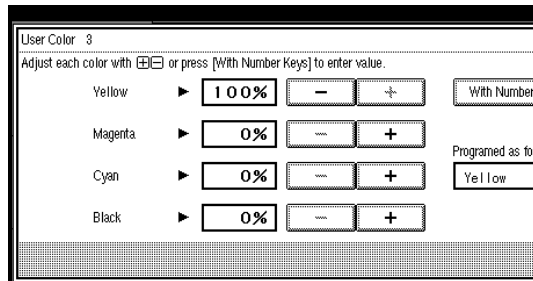

Using [With Number Keys]

1 Press [With Number Keys].

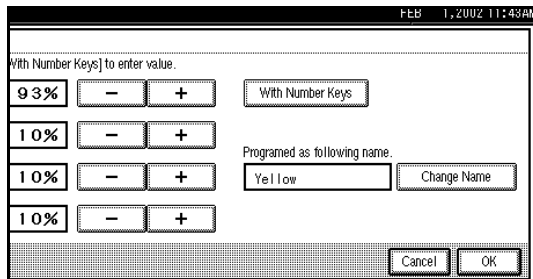

2 Enter the density in percentages (%) using the number keys, and then press [#].

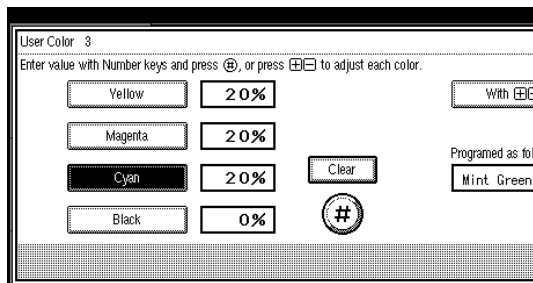

Note

- If you want to use [+] or [-], press [With + -].

- To change the density entered, press [Clear] or the [Clear/Stop] key, and then enter the correct density.
- Repeat step 2 if you want to specify the density of multiple colors.

7 Check densities and names of each color, and then press [OK].

Note

- If you want to rename colors, press [Change Name] and enter a color name of up to 16 characters. After entering the color name, press [OK]. ⇒ “Entering Text”, Administrator Reference 2 Copier System Edition

8 Press [Exit].



Mixing Colors Manually with the Number Keys

1 Press the **[Adjust/Program Color]** key.

The **Adjust/Program Color** indicator lights up.

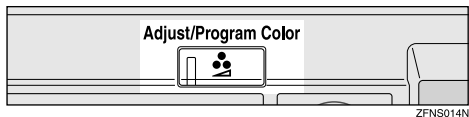

2 Press **[User Color]**.

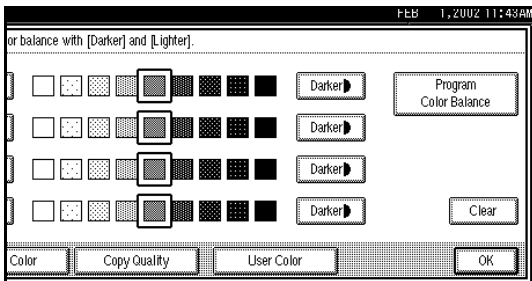

3 Make sure that **[Program]** is selected.

4 Select the number (**[1*Not programmed]** to **[15*Not programmed]**) that you want to store the user color in.

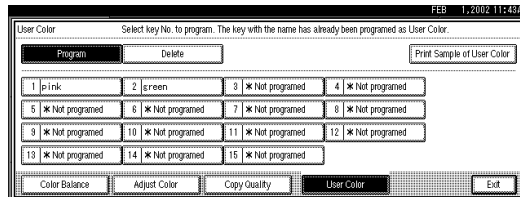

Note

- The contents of the user color will change when selecting the number already displayed by the color name.

5 Press **[Custom Setting]**.

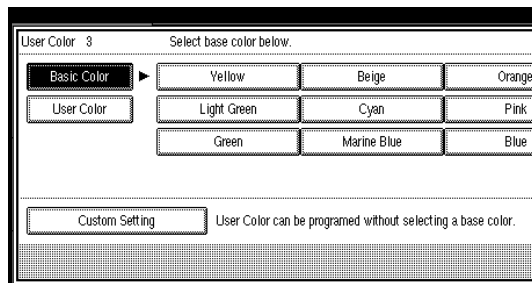



- 6** Select the color that you want to adjust.

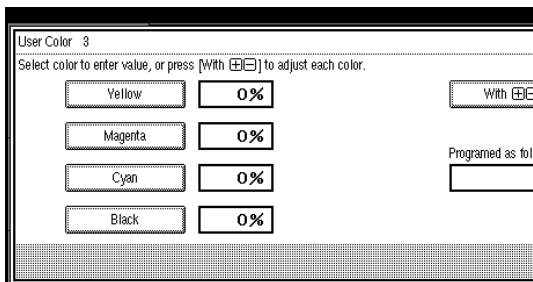

- 7** Enter the density in percentages (%) with the number keys, and then press [#].

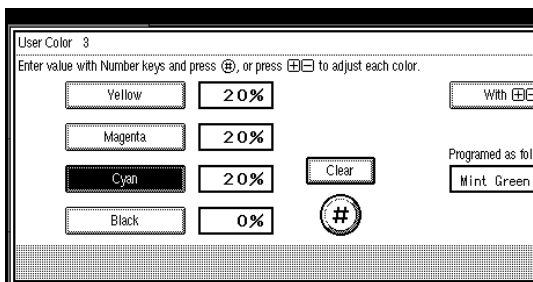

 **Note**

- If you want to use **[+]** or **[-]**, press **[With + -]**.
- To change the number, press **[Clear]** or the **[Clear/Stop]** key.

- 8** Check the names of each color, and then press **[OK]**.

 **Note**

- If you want to rename colors, press **[Change Name]** and enter a color name of up to 16 characters. After entering the color name, press **[OK]**. ⇒ "Entering Text", Administrator Reference 2 Copier System Edition
- Repeat steps **6** to **7** if you want to specify the density of multiple colors.

- 9** Press **[Exit]**.



Deleting User Colors

Limitation

- The colors registered in the program and the registered colors in use cannot be deleted.

1 Press the [Adjust/Program Color] key.

The **Adjust/Program Color** indicator lights up.

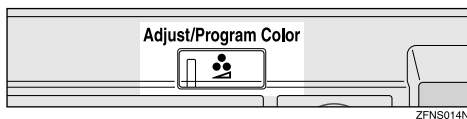

2 Press [User Color].

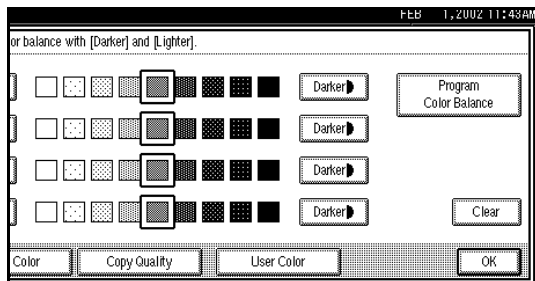

3 Press [Delete].

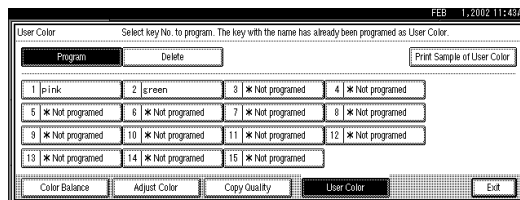

4 Select the number of the user color you want to delete.

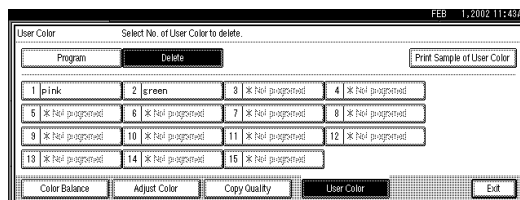

5 Press [Delete].

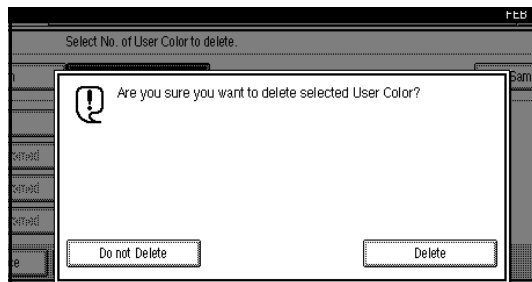

**Note**

- ❑ Press [Do not Delete] if you do not want to delete.

6 Press [Exit].

Sampling the User Colors



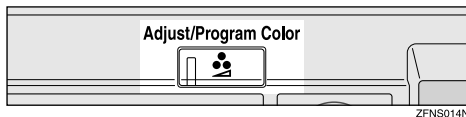

1 Press the [Adjust/Program Color] key.

The **Adjust/Program Color** indicator lights up.

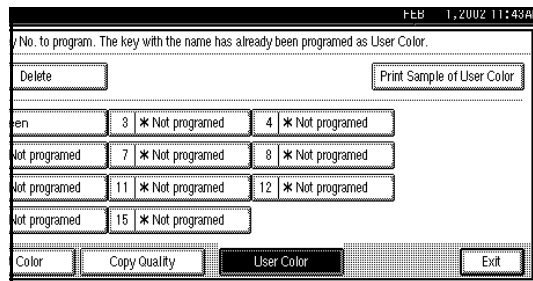
**2** Press [User Color].**3** Make sure the copy paper, and then press [Print Sample of User Color].

The Sample of User Color is printed.

**Note**

- ❑ The sample will be copied on a A4 , 8 1/2" x 11"  sheet or a A3 , 11" x 17"  sheet.



Job Preset

If a long copy job is in progress and you do not wish to wait for it to finish, you can use this function to set up the next copy job in advance. When the current copy job is finished, your copy job will be started automatically.

Note

- When an original has been set and reserved in the optional document feeder (ADF), the reservation will be cleared if the original is removed.
- If a paper jam occurs during the reservation, the reservation will be cleared.

1 Press [Next Job] when “Copying” is displayed.

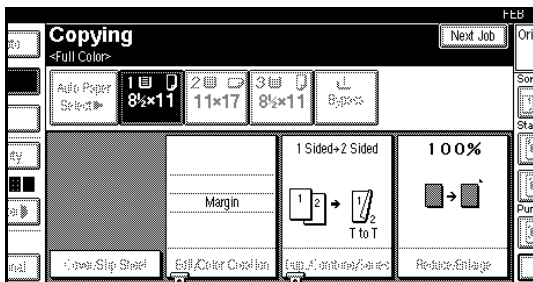

2 Make sure “Ready” is displayed, and then set up the next copy job.

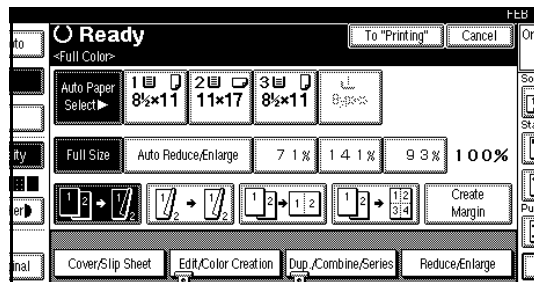

Note

- To cancel this job, press [Cancel].

3 Place your originals, and then press the [Start] key.



4 Press [To "Printing"].

The screen returns to the initial copy display. After the current copy job, the next job starts automatically.

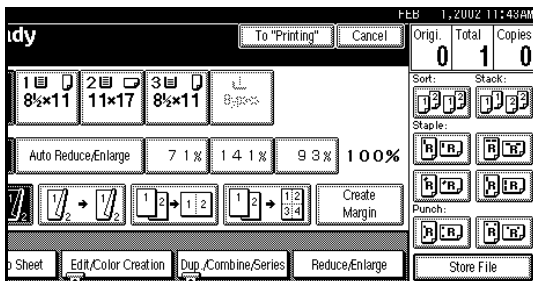

Note

- You can switch the display to the current copy job by pressing [To "Printing"]. You can switch the display to the preset job by pressing [To "Reserving"].

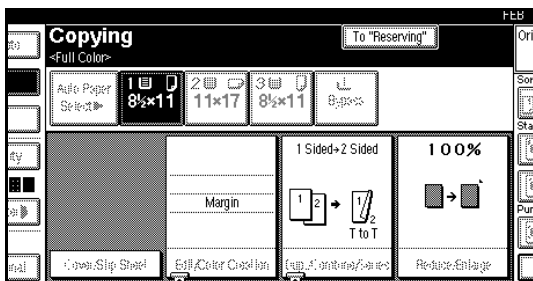



Other Functions

Energy Saver Mode

If you do not operate the machine for a certain period after copying or when you press the **[Energy Saver]** key, the display disappears and the machine enters Energy Saver mode. When you press the **[Energy Saver]** key again, the machine returns to the ready condition. In Energy Saver mode, the machine uses less electricity.

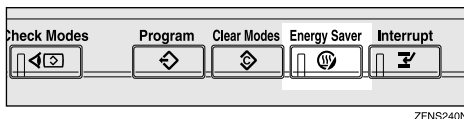

Note

- If you press the **[Energy Saver]** key during an operation, the current settings will be cleared.
- It takes about 3 seconds to return to the ready condition from Energy Saver mode.

Reference

The time for activating the “Energy Saver” mode can be changed in the System Settings.
⇒ “Panel Off Timer”, Administrator Reference
2 Copier System Edition

Auto Start

With this function you can automatically start copying when the machine is on standby.

- 1** While “Please wait.” is displayed, make the copy settings.
- 2** Place your originals.
- 3** Press the **[Start]** key.

The start lamp blinks.

Note

- To cancel the above procedure, press the **[Clear/Stop]** key.



Interrupt Copy

Use this function if you wish to interrupt a long copy job to make urgently needed copies.

Limitation

- You cannot use the Interrupt Copy function when scanning fax and scanner originals.

Note

- The procedure for making interrupt copies depends on the operation the machine is currently carrying out.

To Interrupt an Original Being Fed Using the Optional Document Feeder (ADF)

1 Press the **[Interrupt]** key.

The **Interrupt** indicator lights up and scanning stops.

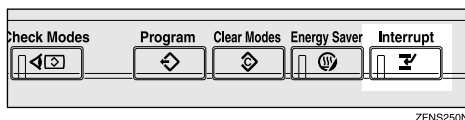

2 Remove the originals that were being copied, and then place the originals you want to copy.

3 Press the **[Start]** key.

The machine starts making your copies.

4 When your copy job is finished, remove your originals and copies.

5 Press the **[Interrupt]** key again.

The **Interrupt** indicator goes off.

6 When the display prompts you, replace the originals that were being copied before.

Note

- When the “Reset * originals.” message appears, remove the original after scanning, and then re-set the original.

7 Press the **[Start]** key.

Copying will restart.

Note

- The previous copy job settings will be restored and the machine will continue copying from where it left off.



To Interrupt Copying after All Originals Have been Fed Using the Optional Document Feeder (ADF) or Exposure Glass

1 Press the **[Interrupt]** key.

The **Interrupt** indicator lights up.

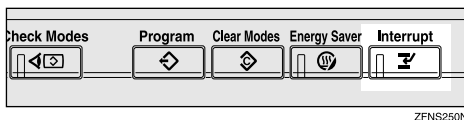

Note

- Copying will not stop yet.

2 Place your originals.

3 Press the **[Start]** key.

The machine stops the original job and starts copying your original.

4 When copying is complete, remove your originals and copies.

5 Press the **[Interrupt]** key again.

The **Interrupt** indicator goes off.

Note

- The previous copy job settings will be restored and the machine will continue copying from where it left off.

Sample Copy

The optional hard disk unit (40 GB) is required.

Use this function to check a copy set before making a long copy run.

Limitation

- This function can be used only when the Sort function has been turned on.
- You cannot use Sample Copy when using the Bypass Tray.

1 Select **Sort** and any other functions, and then enter the number of copy sets to be made.

2 Place your originals.



3 Press the **[Sample Copy]** key.

One copy set is delivered for sample copying.

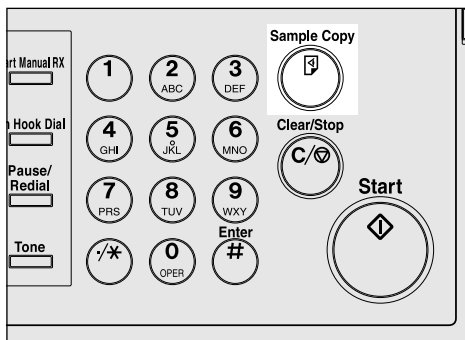

ZFNS015N

Note

- ❑ If you press **[Suspend]** after checking the results, return to step 1 to adjust the copy settings as necessary. You can change the settings for Staple, Punch, Duplex (2 Sided → 1 Sided, 1 Sided → 2 Sided), Copy Orientation, Margin Adjust, and Cover/Slip Sheet. However, depending on the combination of functions, you may not be able to change some settings.
- ❑ When pressing the **[Start]** key or the **[Sample Copy]** key, a sample copy will be taken without reducing the number of the set.

4 After checking the results, press **[Print]** if the sample is acceptable.

The number of copies made is the number you specified minus one for the sample copy.

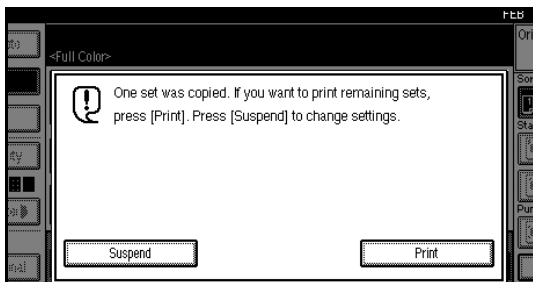



Combination Chart

- : means that these modes can be used together.
- ×: means that these modes cannot be used together. The mode you selected before will be the mode you will work in.
- : means that these modes cannot be used together. The mode you selected after will be the mode you will work in.

The following chart shows the combinations of modes.

| Mode | | <i>Mode after you select</i> | | | | | | | | | | | | | | | | | | | | | | | | | | | | | | | | | | | | | | | | | | | | | | | | |
|-------------------------------------|------------------------|-------------------------------------|----------------------|----------------------|--------------------|----------------------|------------|-----------|---------------|--------------|-------------------|---------------------|------------------------------|-----------------------|---------------------|--------------------|----------------|-------------------|--------|---------|-------------------|-------------------|---------------|-------------------|-----------------------|-------------------|-----------|--------------|--------------|-------------|-------------|------------|------|-------------|-------|--------|-------|-----------------|---|---|---|---|---|---|---|---|---|---|---|---|
| Mode before you select | <i>Mode</i> | Mixed Size Mode | Custom Size Original | Original Orientation | Auto Image Density | Manual Image Density | Full Color | Two Color | Red and Black | Single Color | Auto Paper Select | Manual Paper Select | Copying from the Bypass Tray | Preset Reduce/Enlarge | Auto Reduce/Enlarge | Create Margin Mode | Book → 1 Sided | 2 Sided → 1 Sided | Duplex | Combine | 1 Sided → 2 Sided | 2 Sided → 2 Sided | Double Copies | Whole Area Repeat | Specified Area Repeat | Margin Adjustment | Centering | Center Erase | Border Erase | Erase Color | Front Cover | Slip Sheet | Sort | Rotate Sort | Stack | Staple | Punch | Document Server | | | | | | | | | | | | |
| | Mixed Size Mode | | ○ | × | ○ | ○ | ○ | ○ | ○ | ○ | ○ | ○ | ○ | ○ | ○ | ○ | ○ | ○ | ○ | ○ | ○ | ○ | ○ | ○ | ○ | ○ | ○ | ○ | ○ | ○ | ○ | ○ | ○ | ○ | ○ | ○ | ○ | ○ | ○ | ○ | ○ | ○ | ○ | ○ | | | | | | |
| Custom Size Original | | × | ○ | ○ | ○ | ○ | ○ | ○ | ○ | ○ | ○ | ○ | ○ | ○ | ○ | ○ | ○ | ○ | ○ | ○ | ○ | ○ | ○ | ○ | ○ | ○ | ○ | ○ | ○ | ○ | ○ | ○ | ○ | ○ | ○ | ○ | ○ | ○ | ○ | ○ | ○ | ○ | ○ | ○ | ○ | | | | | |
| Original Orientation | | ○ | ○ | ○ | ○ | ○ | ○ | ○ | ○ | ○ | ○ | ○ | ○ | ○ | ○ | ○ | ○ | ○ | ○ | ○ | ○ | ○ | ○ | ○ | ○ | ○ | ○ | ○ | ○ | ○ | ○ | ○ | ○ | ○ | ○ | ○ | ○ | ○ | ○ | ○ | ○ | ○ | ○ | ○ | ○ | ○ | | | | |
| Auto Image Density | | ○ | ○ | ○ | ○ | ○ | ○ | ○ | ○ | ○ | ○ | ○ | ○ | ○ | ○ | ○ | ○ | ○ | ○ | ○ | ○ | ○ | ○ | ○ | ○ | ○ | ○ | ○ | ○ | ○ | ○ | ○ | ○ | ○ | ○ | ○ | ○ | ○ | ○ | ○ | ○ | ○ | ○ | ○ | ○ | ○ | ○ | | | |
| Manual Image Density | | ○ | ○ | ○ | ○ | ○ | ○ | ○ | ○ | ○ | ○ | ○ | ○ | ○ | ○ | ○ | ○ | ○ | ○ | ○ | ○ | ○ | ○ | ○ | ○ | ○ | ○ | ○ | ○ | ○ | ○ | ○ | ○ | ○ | ○ | ○ | ○ | ○ | ○ | ○ | ○ | ○ | ○ | ○ | ○ | ○ | ○ | | | |
| Full Color | | ○ | ○ | ○ | ○ | ○ | ○ | ○ | ○ | ○ | ○ | ○ | ○ | ○ | ○ | ○ | ○ | ○ | ○ | ○ | ○ | ○ | ○ | ○ | ○ | ○ | ○ | ○ | ○ | ○ | ○ | ○ | ○ | ○ | ○ | ○ | ○ | ○ | ○ | ○ | ○ | ○ | ○ | ○ | ○ | ○ | ○ | | | |
| Two Color | | ○ | ○ | ○ | ○ | ○ | ○ | ○ | ○ | ○ | ○ | ○ | ○ | ○ | ○ | ○ | ○ | ○ | ○ | ○ | ○ | ○ | ○ | ○ | ○ | ○ | ○ | ○ | ○ | ○ | ○ | ○ | ○ | ○ | ○ | ○ | ○ | ○ | ○ | ○ | ○ | ○ | ○ | ○ | ○ | ○ | ○ | ○ | | |
| Red and Black | | ○ | ○ | ○ | ○ | ○ | ○ | ○ | ○ | ○ | ○ | ○ | ○ | ○ | ○ | ○ | ○ | ○ | ○ | ○ | ○ | ○ | ○ | ○ | ○ | ○ | ○ | ○ | ○ | ○ | ○ | ○ | ○ | ○ | ○ | ○ | ○ | ○ | ○ | ○ | ○ | ○ | ○ | ○ | ○ | ○ | ○ | ○ | ○ | |
| Single Color | | ○ | ○ | ○ | ○ | ○ | ○ | ○ | ○ | ○ | ○ | ○ | ○ | ○ | ○ | ○ | ○ | ○ | ○ | ○ | ○ | ○ | ○ | ○ | ○ | ○ | ○ | ○ | ○ | ○ | ○ | ○ | ○ | ○ | ○ | ○ | ○ | ○ | ○ | ○ | ○ | ○ | ○ | ○ | ○ | ○ | ○ | ○ | ○ | ○ |
| Auto Paper Select | | ○ | ○ | ○ | ○ | ○ | ○ | ○ | ○ | ○ | ○ | ○ | ○ | ○ | ○ | ○ | ○ | ○ | ○ | ○ | ○ | ○ | ○ | ○ | ○ | ○ | ○ | ○ | ○ | ○ | ○ | ○ | ○ | ○ | ○ | ○ | ○ | ○ | ○ | ○ | ○ | ○ | ○ | ○ | ○ | ○ | ○ | ○ | ○ | |
| Manual Paper Select | | ○ | ○ | ○ | ○ | ○ | ○ | ○ | ○ | ○ | ○ | ○ | ○ | ○ | ○ | ○ | ○ | ○ | ○ | ○ | ○ | ○ | ○ | ○ | ○ | ○ | ○ | ○ | ○ | ○ | ○ | ○ | ○ | ○ | ○ | ○ | ○ | ○ | ○ | ○ | ○ | ○ | ○ | ○ | ○ | ○ | ○ | ○ | ○ | |
| Copying from the Bypass Tray | | ○ | ○ | ○ | ○ | ○ | ○ | ○ | ○ | ○ | ○ | ○ | ○ | ○ | ○ | ○ | ○ | ○ | ○ | ○ | ○ | ○ | ○ | ○ | ○ | ○ | ○ | ○ | ○ | ○ | ○ | ○ | ○ | ○ | ○ | ○ | ○ | ○ | ○ | ○ | ○ | ○ | ○ | ○ | ○ | ○ | ○ | ○ | ○ | |
| Preset Reduce/Enlarge | | ○ | ○ | ○ | ○ | ○ | ○ | ○ | ○ | ○ | ○ | ○ | ○ | ○ | ○ | ○ | ○ | ○ | ○ | ○ | ○ | ○ | ○ | ○ | ○ | ○ | ○ | ○ | ○ | ○ | ○ | ○ | ○ | ○ | ○ | ○ | ○ | ○ | ○ | ○ | ○ | ○ | ○ | ○ | ○ | ○ | ○ | ○ | ○ | |
| Auto Reduce/Enlarge | | ○ | ○ | ○ | ○ | ○ | ○ | ○ | ○ | ○ | ○ | ○ | ○ | ○ | ○ | ○ | ○ | ○ | ○ | ○ | ○ | ○ | ○ | ○ | ○ | ○ | ○ | ○ | ○ | ○ | ○ | ○ | ○ | ○ | ○ | ○ | ○ | ○ | ○ | ○ | ○ | ○ | ○ | ○ | ○ | ○ | ○ | ○ | ○ | |
| Create Margin Mode | | ○ | ○ | ○ | ○ | ○ | ○ | ○ | ○ | ○ | ○ | ○ | ○ | ○ | ○ | ○ | ○ | ○ | ○ | ○ | ○ | ○ | ○ | ○ | ○ | ○ | ○ | ○ | ○ | ○ | ○ | ○ | ○ | ○ | ○ | ○ | ○ | ○ | ○ | ○ | ○ | ○ | ○ | ○ | ○ | ○ | ○ | ○ | ○ | |
| Book → 1 Sided | | ○ | ○ | ○ | ○ | ○ | ○ | ○ | ○ | ○ | ○ | ○ | ○ | ○ | ○ | ○ | ○ | ○ | ○ | ○ | ○ | ○ | ○ | ○ | ○ | ○ | ○ | ○ | ○ | ○ | ○ | ○ | ○ | ○ | ○ | ○ | ○ | ○ | ○ | ○ | ○ | ○ | ○ | ○ | ○ | ○ | ○ | ○ | ○ | |
| 2 Sided → 1 Sided | | ○ | ○ | ○ | ○ | ○ | ○ | ○ | ○ | ○ | ○ | ○ | ○ | ○ | ○ | ○ | ○ | ○ | ○ | ○ | ○ | ○ | ○ | ○ | ○ | ○ | ○ | ○ | ○ | ○ | ○ | ○ | ○ | ○ | ○ | ○ | ○ | ○ | ○ | ○ | ○ | ○ | ○ | ○ | ○ | ○ | ○ | ○ | ○ | |
| Duplex | | ○ | ○ | ○ | ○ | ○ | ○ | ○ | ○ | ○ | ○ | ○ | ○ | ○ | ○ | ○ | ○ | ○ | ○ | ○ | ○ | ○ | ○ | ○ | ○ | ○ | ○ | ○ | ○ | ○ | ○ | ○ | ○ | ○ | ○ | ○ | ○ | ○ | ○ | ○ | ○ | ○ | ○ | ○ | ○ | ○ | ○ | ○ | ○ | ○ |
| Combine | | ○ | ○ | ○ | ○ | ○ | ○ | ○ | ○ | ○ | ○ | ○ | ○ | ○ | ○ | ○ | ○ | ○ | ○ | ○ | ○ | ○ | ○ | ○ | ○ | ○ | ○ | ○ | ○ | ○ | ○ | ○ | ○ | ○ | ○ | ○ | ○ | ○ | ○ | ○ | ○ | ○ | ○ | ○ | ○ | ○ | ○ | ○ | ○ | |

*1 means that the "1 Sided → 2 Sided" mode and "Cover" mode cannot be used together.
 *2 means that both modes cannot be used together when placing paper with widths of over 305mm(12") or large paper with areas of more than 297 x 432mm(11" x 17") in the Bypass Tray.
 *3 means that both modes cannot be used together when placing paper with widths of over 305mm(12") in the Bypass Tray.



The following chart shows the combinations of modes.

| Mode | Mode after you select | | | | | | | | | | | | | | | | | | | | | | | | | | | | | | | | | | | | | | |
|-----------------------|-----------------------|----------------------|----------------------|--------------------|----------------------|------------|-----------|---------------|--------------|-------------------|---------------------|------------------------------|---------------------|--------------------|----------------|-------------------|--------|---------|-------------------|-------------------|---------------|-------------------|-----------------------|-------------------|-----------|--------------|--------------|-------------|-------------|------------|------|-------------|-------|--------|-------|-----------------|---|---|---|
| | Mixed Size Mode | Custom Size Original | Original Orientation | Auto Image Density | Manual Image Density | Full Color | Two Color | Red and Black | Single Color | Auto Paper Select | Manual Paper Select | Copying from the Bypass Tray | Auto Reduce/Enlarge | Create Margin Mode | Book → 1 Sided | 2 Sided → 1 Sided | Duplex | Combine | 1 Sided → 2 Sided | 2 Sided → 2 Sided | Double Copies | Whole Area Repeat | Specified Area Repeat | Margin Adjustment | Centering | Center Erase | Border Erase | Erase Color | Front Cover | Slip Sheet | Sort | Rotate Sort | Stack | Staple | Punch | Document Server | | | |
| 1 Sided → 2 Sided | O | O | O | O | O | O | O | O | O | O | O | O | O | O | O | O | O | O | O | O | O | O | O | O | O | O | O | O | O | O | O | O | O | O | O | O | O | O | |
| 2 Sided → 2 Sided | O | O | x | x | O | O | O | O | O | O | O | O | O | O | O | O | O | O | O | O | O | O | O | O | O | O | O | O | O | O | O | O | O | O | O | O | O | O | |
| Double Copies | O | O | O | O | O | O | O | O | O | O | O | O | O | O | O | O | O | O | O | O | O | O | O | O | O | O | O | O | O | O | O | O | O | O | O | O | O | O | |
| Whole Area Repeat | O | O | O | O | O | O | O | O | O | O | O | O | O | O | O | O | O | O | O | O | O | O | O | O | O | O | O | O | O | O | O | O | O | O | O | O | O | O | |
| Specified Area Repeat | O | O | O | O | O | O | O | O | O | O | O | O | O | O | O | O | O | O | O | O | O | O | O | O | O | O | O | O | O | O | O | O | O | O | O | O | O | O | |
| Margin Adjustment | O | O | O | O | O | O | O | O | O | O | O | O | O | O | O | O | O | O | O | O | O | O | O | O | O | O | O | O | O | O | O | O | O | O | O | O | O | O | |
| Centering | O | O | O | O | O | O | O | O | O | O | O | O | O | O | O | O | O | O | O | O | O | O | O | O | O | O | O | O | O | O | O | O | O | O | O | O | O | O | |
| Center Erase | O | O | O | O | O | O | O | O | O | O | O | O | O | O | O | O | O | O | O | O | O | O | O | O | O | O | O | O | O | O | O | O | O | O | O | O | O | O | |
| Border Erase | O | O | O | O | O | O | O | O | O | O | O | O | O | O | O | O | O | O | O | O | O | O | O | O | O | O | O | O | O | O | O | O | O | O | O | O | O | O | |
| Erase Color | O | O | O | x | O | O | O | O | O | O | O | O | O | O | O | O | O | O | O | O | O | O | O | O | O | O | O | O | O | O | O | O | O | O | O | O | O | O | O |
| Front Cover | O | O | O | O | O | O | O | O | O | O | O | O | O | O | O | O | O | O | O | O | O | O | O | O | O | O | O | O | O | O | O | O | O | O | O | O | O | O | O |
| Slip Sheet | O | O | O | O | O | O | O | O | O | O | O | O | O | O | O | O | O | O | O | O | O | O | O | O | O | O | O | O | O | O | O | O | O | O | O | O | O | O | O |
| Sort | O | O | O | O | O | O | O | O | O | O | O | O | O | O | O | O | O | O | O | O | O | O | O | O | O | O | O | O | O | O | O | O | O | O | O | O | O | O | O |
| Rotate Sort | O | O | O | O | O | O | O | O | O | O | O | O | O | O | O | O | O | O | O | O | O | O | O | O | O | O | O | O | O | O | O | O | O | O | O | O | O | O | O |
| Stack | O | O | O | O | O | O | O | O | O | O | O | O | O | O | O | O | O | O | O | O | O | O | O | O | O | O | O | O | O | O | O | O | O | O | O | O | O | O | O |
| Staple | O | O | O | O | O | O | O | O | O | O | O | O | O | O | O | O | O | O | O | O | O | O | O | O | O | O | O | O | O | O | O | O | O | O | O | O | O | O | O |
| Punch | O | O | O | O | O | O | O | O | O | O | O | O | O | O | O | O | O | O | O | O | O | O | O | O | O | O | O | O | O | O | O | O | O | O | O | O | O | O | O |
| Document Server | O | O | O | O | O | O | O | O | O | O | O | O | O | O | O | O | O | O | O | O | O | O | O | O | O | O | O | O | O | O | O | O | O | O | O | O | O | O | O |

*1 means that the "1 Sided → 2 Sided" mode and "Cover" mode cannot be used together.
 *2 means that both modes cannot be used together when placing paper with widths of over 305mm(12") or large paper with areas of more than 297 x 432mm(11" x 17") in the Bypass Tray.
 *3 means that both modes cannot be used together when placing paper with widths of over 305mm(12") in the Bypass Tray.
 *4 means that the "Staple" (Top 2) mode and "Punch" (Left position) mode cannot be used together.



2. Troubleshooting

If You Cannot Make Clear Copies

| Problem | Cause | Solution & Reference |
|---|--|---|
| Copies appear dirty. | The image density is too dark. | Adjust the image density. ⇒ “Adjusting Copy Image Density”, <i>Basic Features</i> manual |
| | Auto Image Density is not selected. | Select Auto Image Density. ⇒ “Adjusting Copy Image Density”, <i>Basic Features</i> manual |
| The reverse side of an original image is copied. | The image density is too dark. | Adjust the image density. ⇒ “Adjusting Copy Image Density”, <i>Basic Features</i> manual |
| | Auto Image Density is not selected. | Select Auto Image Density. ⇒ “Adjusting Copy Image Density”, <i>Basic Features</i> manual |
| A shadow appears on copies if you use pasted originals. | The image density is too dark. | Adjust the image density. ⇒ “Adjusting Copy Image Density”, <i>Basic Features</i> manual |
| | | Change the orientation of the original. |
| | | Put mending tape on the pasted part. |
| The same copy area is dirty whenever making copies. | The exposure glass or optional document feeder (ADF) is dirty. | Clean them. ⇒ “Cleaning the Exposure Glass”, “When using the document feeder (ADF)”, <i>Maintenance Guide 2 Copier System Edition</i> |



| Problem | Cause | Solution & Reference |
|------------------------------------|---------------------------------------|--|
| Copies are too light. | The image density is too light. | Adjust the image density. ⇒ “Adjusting Copy Image Density”, <i>Basic Features</i> manual |
| | The paper size is not appropriate. | Use the recommended paper. ⇒ “Sizes and Weights Recommended Originals”, Maintenance Guide 1 Copier System Edition  Note <input type="checkbox"/> A light copy may result when you use damp, rough grain or coated paper. |
| | Toner cartridge is almost empty. | Add toner. ⇒ “Replacing the Toner Cartridge”, Maintenance Guide 2 Copier System Edition |
| Parts of the image are not copied. | The original is not placed correctly. | Place originals correctly. ⇒ “Placing Original”, <i>Basic Features</i> manual |
| | An improper paper size is selected. | Select the proper paper size. |
| Copies are blank. | The original is not placed correctly. | When using the exposure glass, face the originals down. When using the optional document feeder (ADF), face them up. ⇒ “Placing Originals on the Exposure Glass”, <i>Basic Features</i> manual |



| Problem | Cause | Solution & Reference |
|---|---|--|
| <p>A moiré pattern is produced on copies.</p>  | <p>Your original has a dot pattern image or many lines.</p> | <p>Place the original on the exposure glass at a slight angle.</p> |





When copying doesn't start

When a Message is Displayed

The following chart describes displayed messages as well as what to do when they appear.

| Message | Cause | Solution & Reference |
|------------------------------|--|---|
| Cannot detect original size. | An original with a size difficult to detect has been placed. ⇒ p.136 “Sizes Difficult to Detect” | Do not use Auto Paper Select. In paper selection use other procedures except for paper specified magnification for Reduce/Enlarge copies. Make sure that the original is correctly placed on the exposure glass. ⇒ “Placing Originals on the Exposure Glass”, <i>Basic Features</i> manual |
| | Originals have not been placed. | Place originals in the machine. |
| Check original orientation. | The orientation of the original is not correct. | Change the orientation of the original. |
| Maximum number of sets is *. | The number of copies exceeds the limit. | You can change the maximum number of sets to be copied one at a time. ⇒ p.107 “Max. Copy Quantity” |
| Check paper size. | The paper is not suitable. | When pressing the [Start] key, copying will be done on the selected paper. |



| Message | Cause | Solution & Reference |
|--|---|--|
| Rotate Sort is not available with this paper size. | Paper which cannot be sorted and rotated has been selected. | Select a paper size which can be sorted and rotated. ⇒ “Sort”, <i>Basic Features</i> manual |
| Cannot punch paper of this size. | Paper which cannot be punched has been selected. | Paper sizes which can be punched: A3, B4, A4, B5, A5, 11"×17", 8½"×14", 8½"×11". Choose from the above sizes. |
| Stapling capacity exceeded. | The number of pages has exceeded the maximum stapling capacity. | Copy within the stapling capacity. ⇒ “Staple”, <i>Basic Features</i> manual |
| Cannot staple paper of this size. | Paper which cannot be stapled has been selected. | Select a paper size which can be stapled. ⇒ “Staple”, <i>Basic Features</i> manual |
| Duplex is not available with this paper size. | Paper which cannot be duplex copied has been selected. | Paper sizes which can be duplex copied are: A3, B4, A4, B5, A5, 11"×17", 8½"×14", 8½"×11", 5½"×8½", 8"×13". Choose from the above sizes. |





If You Cannot Make Copies As You Want

General

| Problem | Cause | Solution & Reference |
|--|---|--|
| Copies are not stapled. | There are jammed staples in the stapler. | Remove jammed staples. ⇒ “Removing Jammed Staples”, Maintenance Guide 2 Copier System Edition  Note <input type="checkbox"/> After removing jammed staples, staples might not be ejected the first few times you try to use the stapler. |
| | The number of copies exceeds the capacity of the stapler. | Check the stapler capacity. ⇒ “Staple”, <i>Basic Features</i> manual |
| | Copy paper is curled. | Turn the copy paper over in the tray. |
| Staples are wrongly positioned. | Originals are not placed correctly. | Place the original on the upper left corner of the exposure glass. ⇒ “Staple”, <i>Basic Features</i> manual |
| Misfeeds occur frequently. | Copy paper size setting is not correct. | Set the proper paper size. ⇒ “Paper Tray (Tray 1 - 4)”, Administrator Reference 2 Copier System Edition |
| You cannot combine several functions. | Selected functions cannot be used together. | Check the combination of functions and correct the settings. |
| When sorting, the pages are divided into two blocks. | The memory became full in the middle of sorting and the pages were delivered in two blocks. | You can interrupt the copying when the memory becomes full. ⇒ “Staple”, <i>Basic Features</i> manual |



Adjust Image

| Problem | Cause | Solution & Reference |
|---|--|---|
| In Double Copies mode, parts of the original image are not copied. | Combination of original and copy paper is not correct. | Select A3  for A4 originals  , and A4 for A5 originals. |
| In Border, Center, or Center/Border mode, parts of the original image are not copied. | You set a wide erased margin. | Make the margin width narrower. You can adjust it between 2-99mm. ⇒ p.117 “Erase Original Shadow in Combine”, p.117 “Erase Center Width” |
| | Originals are not scanned correctly. | Place the originals correctly. |
| In Margin Adjustment mode, parts of the original image are not copied. | You set a wide erased margin. | Set a narrower margin with the User Tools. You can change it between 0-30 mm. ⇒ p.115 “Front Margin: Left/Right”, p.115 “Back Margin: Left/Right”, p.115 “Front Margin: Top/Bottom”, p.116 “Back Margin: Top/Bottom” |
| | There is a lack of margin space on the opposite side of the binding position. | |
| In Image Repeat mode, the original image is not copied repeatedly. | You selected copy paper the same size as originals, or you did not select the proper reproduction ratio. | Select copy paper larger than the originals. Select the proper reproduction ratio. |



Combine

| Problem | Cause | Solution & Reference |
|------------------------------------|--|---|
| Parts of the image are not copied. | You specified a reproduction ratio that does not match the sizes of your originals and copy paper. | When you specify a reproduction ratio using Manual Paper Select mode, make sure that the ratio matches your originals and the copy paper.  Note <input type="checkbox"/> Select the correct reproduction ratio before using Combine mode. |
| | When you use staple and punch together, extra margin may appear. | Change the orientation of the originals. The blank space can be eliminated by changing the orientation of the originals. However, the punching or stapling location may not be as expected. |
| Order of copies is not correct. | You place the originals in the incorrect order. | When placing a stack of originals in the optional document feeder (ADF), the last page should be on the bottom. If you place an original on the exposure glass, start with the first page to be copied. |

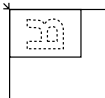
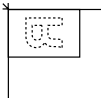

Duplex

| Problem | Cause | Solution & Reference |
|--|--|--|
| Order of copies is not correct. | You placed the originals in the incorrect order. | When placing a stack of originals in the optional document feeder (ADF), the last page should be on the bottom. If you place an original on the exposure glass, start with the first page to be copied. |
| Orientation of copies (Top to Top, or Top to Bottom) is not correct. | You placed the originals in the wrong orientation or the orientation setting is incorrect. | <p>Select the correct orientation, or place originals correctly. ⇒ “Placing Originals”, <i>Basic Features</i> manual</p> <p> Note</p> <p><input type="checkbox"/> If you place A3, 11" × 17" or B4, 8¹/₂" × 14" originals as shown below, select [Top to Bottom] to make copies in “Top to Top” orientation. Or select [Top to Top] to make copies in “Top to Bottom” orientation.</p> <div data-bbox="930 987 1208 1084"></div> <p data-bbox="1163 1088 1208 1101">CP270-A</p> |



When Memory Is Full

Limitation

- If memory is full, Interrupt Copy will not be available.

Note

- If you set “Memory Full Auto Scan Restart” of the User Tools to “Yes”, the memory overflow message will not be displayed, but make Connect Copy for the scanned original automatically. Connect Copy continues scanning and copying until finishing the job. Note that copy sets will be printed out separately by scanning at this time.

| Message | Cause | Solution & Reference |
|--|--|---|
| <p>Memory is full.*originals have been scanned.</p> <p>Press [Print] to copy scanned originals. Do not remove remaining originals.</p> <p> Note</p> <ul style="list-style-type: none"><input type="checkbox"/> Copying will stop and this message will be displayed when the memory is full. | <p>The scanned original exceeds the number of pages that can be stored in memory.</p> | <p>Press [Print] to copy scanned originals and clear the scanning data.</p> <p>Press [Clear] to clear the scanning data and not copy.</p> |
| <p>Press [Continue] to scan and copy remaining originals.</p> <p>[Stop] [Continue]</p> | <p>The machine checks if the remaining original should be copied, after the scanned original has been printed.</p> | <p>To continue copying, remove all copies then press [Continue]. To stop copying, press [Stop].</p> |



Document Server

| Message | Cause | Solution & Reference |
|--|--|--|
| Memory is full.*originals have been scanned. | The scanned original exceeds the number of pages that can be stored in memory. | Delete any unnecessary files and then scan the document again. ⇒ “Deleting Saved Documents”, Administrator Reference 2 Copier System Edition |



Copy Quality

The following are types of copy quality you can make.

❖ Sharp/Soft

For adjusting the outline of an image

❖ Contrast

For adjusting the shades of an image

❖ Background Density

For adjusting the background density of an image

❖ Adjust U.C.R.

For expressing vividly the black areas in an image by adjusting the amount of black toner

❖ Text/Photo Sensitivity

For adjusting the standard level in the text and the photo part of the image, when using “Text/Photo”

Note

- ❑ “Sharp/Soft”, “Contrast” and “Background Density” can each be adjusted. However, their adjustments can affect the level of other functions.

1 Press the **[Adjust/Program Color]** key.

The **Adjust/Program Color** indicator lights up.

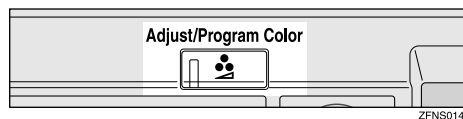

2 Press **[Copy Quality]**.

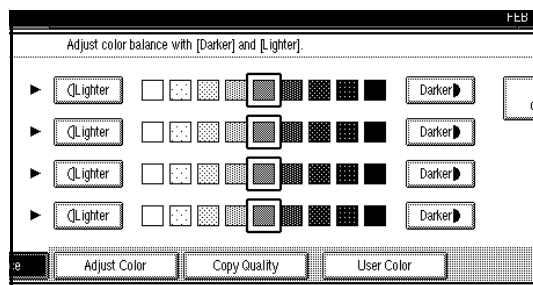

3 Adjust the settings.

Reference

- ⇒ p.86 “Adjusting the Sharp/Soft”
- ⇒ p.86 “Adjusting the Contrast”
- ⇒ p.87 “Adjusting the Background Density”
- ⇒ p.87 “Adjusting the U.C.R.”
- ⇒ p.88 “Adjusting the Text/Photo Sensitivity”



Adjusting the Sharp/Soft

① Adjust by pressing [Soft] or [Sharp].

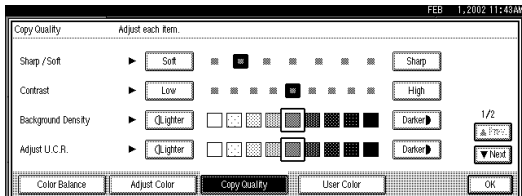

② Press [OK].



Note

- The **Adjust/Program Color** indicator will light up, when adjusting the image.
- The adjusted settings will be deleted and the initial values will return when Auto Clear has been performed, the **[Clear Modes]** key has been pressed, or when the power has been turned off.

Adjusting the Contrast

① Adjust by pressing [Low] or [High].

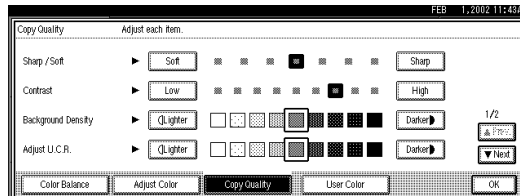

② Press [OK].



Note

- The **Adjust/Program Color** indicator will light up, when adjusting the image.
- The adjusted settings will be deleted and the initial values will return when Auto Clear has been performed, the **[Clear Modes]** key has been pressed, or when the power has been turned off.



Adjusting the Background Density

1 Adjust by pressing [Lighter] or [Darker].

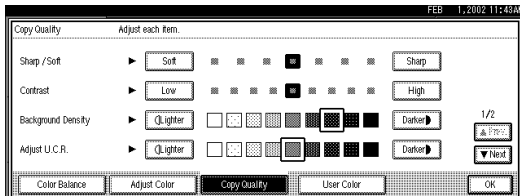

Note

- Adjustments should be made lightly when copying dark textured originals, such as newspapers or recycled paper.
- Adjustments should be made darker when darkening the color of markers or highlighters. However, as the color of highlighters is difficult to reproduce, the copy might not be printed depending on the color, or a different color might be copied.

2 Press [OK].



Note

- The **Adjust/Program Color** indicator will light up, when adjusting the image.

- The adjusted settings will be deleted and the initial values will return when Auto Clear has been performed, the **[Clear Modes]** key has been pressed, or when the power has been turned off.

Adjusting the U.C.R.

1 Adjust by pressing [Lighter] or [Darker].

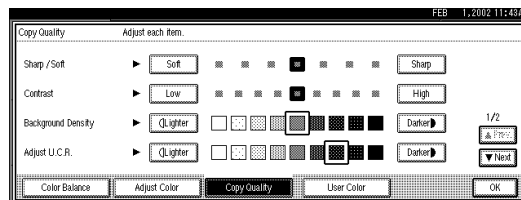

2 Press [OK].



Note

- The **Adjust/Program Color** indicator will light up, when adjusting the image.
- The adjusted settings will be deleted and the initial values will return when Auto Clear has been performed, the **[Clear Modes]** key has been pressed, or when the power has been turned off.

Adjusting the Text/Photo Sensitivity

1 Press [▼Next].

 **Note**

- Press [▲Prev.] to return to the previous screen.

2 Adjust by pressing [Text] or [Photo].

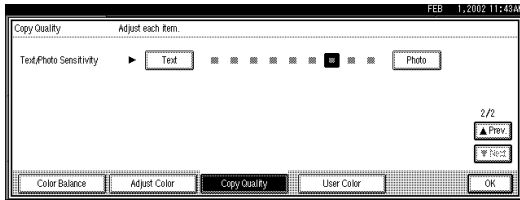

 **Note**

- Make sure to set the indicator toward “Text” when parts of the texts are faded or are not clear. Set to “Photo” when the outline of photos becomes dark.

3 Press [OK].

 **Note**

- The **Adjust/Program Color** indicator will light up, when adjusting the image.

- The adjusted settings will be deleted and the initial values will return when Auto Clear has been performed, the **[Clear Modes]** key has been pressed, or when the power has been turned off.

Auto Color Calibration

1 Press the [User Tools/Counter] key.

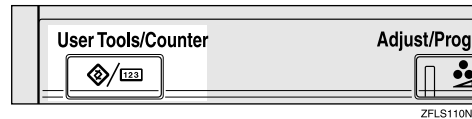

2 Press [Maintenance].

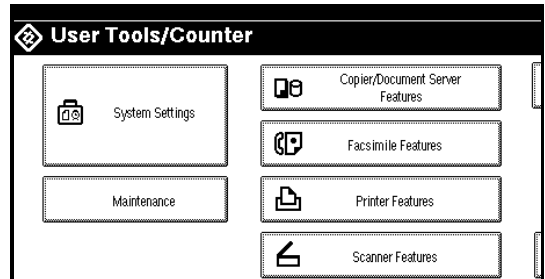



3 Press [Auto Color Calibration].

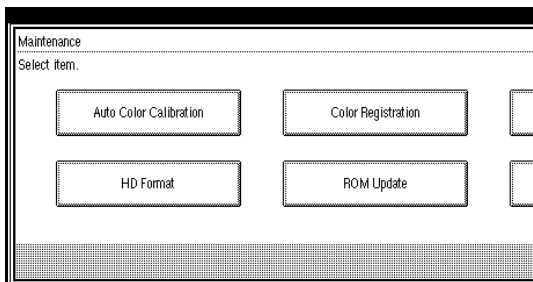



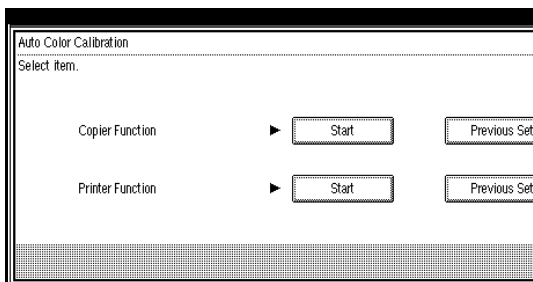

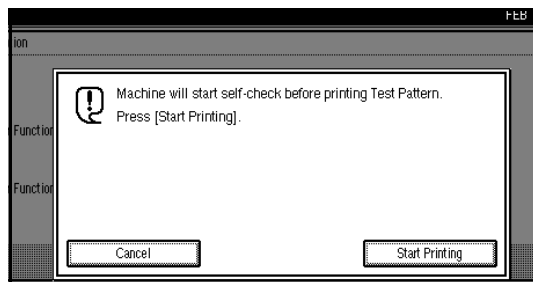

4 Press [Start] on the “Copier Function”.



5 Press [Start Printing] and a test pattern will be printed.



 **Note**

- The test pattern will be printed on an A4 , A3 , 8 1/2" x 11" , 11" x 17"  size page (If A4  is not available then A3 , B4  will be used). Make sure to check the paper set in the paper tray.
- You cannot use the Bypass Tray as the paper tray.
- The counter will not proceed when the test pattern is printed.



6 Place the test pattern on the exposure glass, and then press [Start Scanning].

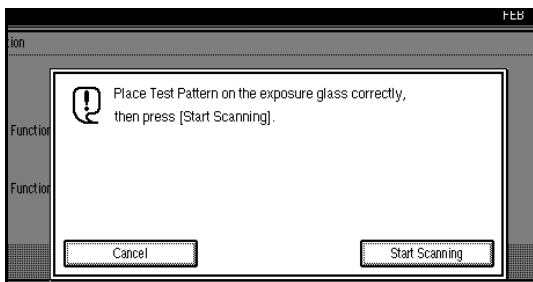

The image will be corrected after “Please wait.” disappears.

Limitation

- ❑ The test pattern will not be read if it is placed in the optional document feeder (ADF).

Note

- ❑ Place the test pattern on the exposure glass in the following way:

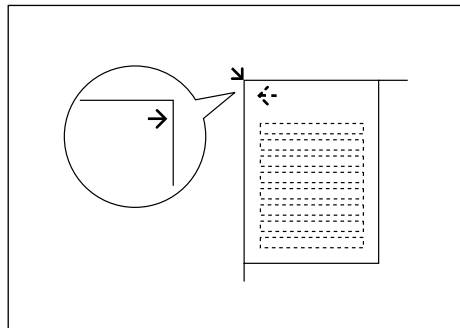

- ❑ When using the optional document feeder (ADF), make sure to place the test pattern on the exposure glass, and then 2 or 3 white sheets, same size as the test pattern, on top of the test pattern.

Returning to the previous setting

Note

- ❑ “Previous Setting” means to return to the previous status before any changes.



- 1 Press [Previous Setting] on the “Copier Function”.

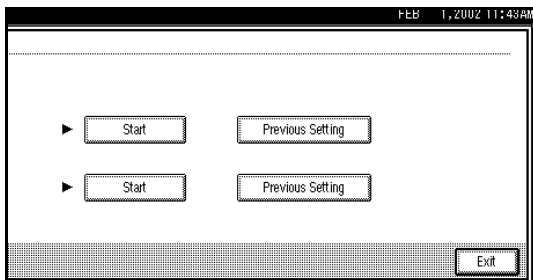

- 2 Press [Yes].

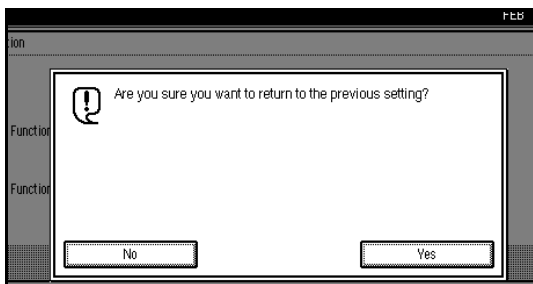

The previous setting is reset.



Note

- If you do not want to return to the previous setting, press [No].



Adjust Color

This function lets you alter up to three single colors by mixing them with adjacent colors in the color circle. For example, yellow can be shifted towards red to make orange, or towards green to make a yellow green. Note that only areas of the image containing this color will be modified.

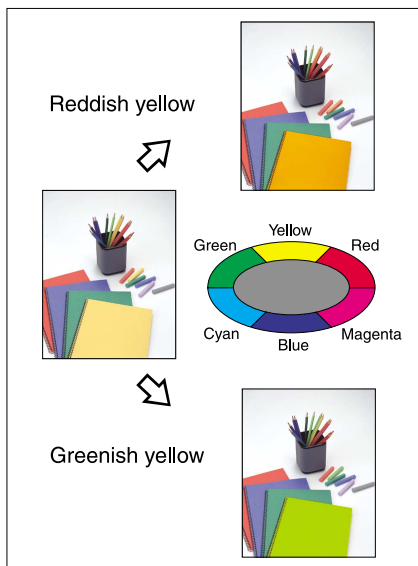

GCLCPGE

Note

- You can set up to 3 colors from yellow, red, magenta, blue, cyan, or green.
- This function is only available in Full Color mode.

1 Press the **[Adjust/Program Color]** key.

The **Adjust/Program Color** indicator lights up.

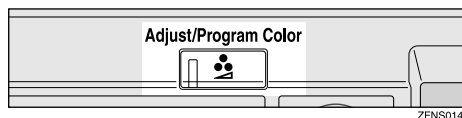

ZFNS014N

2 Press **[Adjust Color]**.

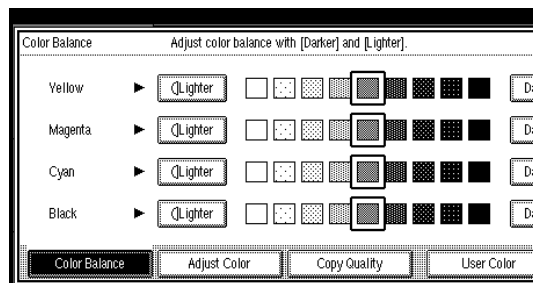

The color circle appears.



3 Select the colors you want to adjust.

You can select up to 3 colors.

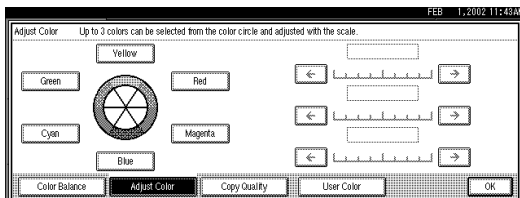

- The adjusted settings will be deleted and the initial values will return when Auto Clear has been performed, the **[Clear Modes]** key has been pressed, or when the power has been turned off.

4 Adjust the color using [←] or [→].

The color can be adjusted up to 9 levels.

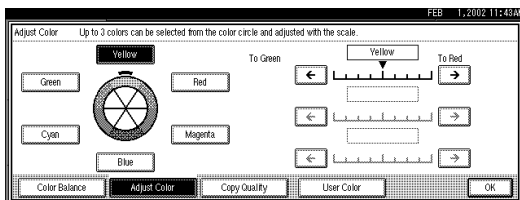

Note

- Level 5 is the initial value.

5 Press [OK].

Note

- The **Adjust/Program Color** indicator will light up, when adjusting the color.





Color Balance

This function allows you to control the overall color tone of copies by adjusting the Yellow, Magenta, Cyan and Black color balance. Nine levels of tone are available.

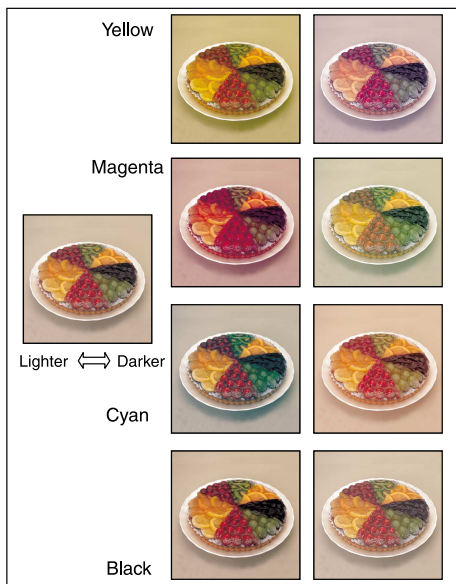

Note

- ❑ You can register the adjusted contents (using the Color Balance Program) and print a sample of the adjusted color (using the Color Balance Monitor).

1 Press the **[Adjust/Program Color]** key.

The **Adjust/Program Color** indicator lights up.

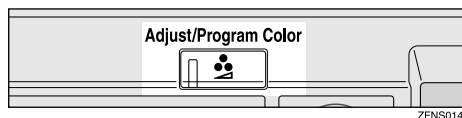

2 Make sure that **[Color Balance]** is selected.

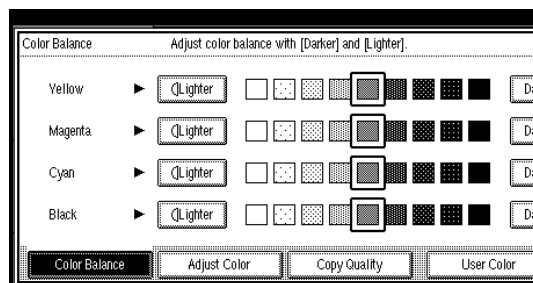

3 Adjust by pressing [Lighter] or [Darker].

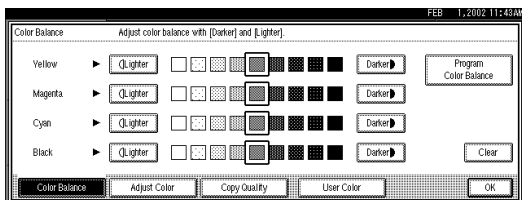

4 Press [OK].

Note

- The **Adjust/Program Color** indicator will light up, when adjusting the color balance.
- The adjusted settings will be deleted and the initial values will return when Auto Clear has been performed, the **[Clear Modes]** key has been pressed, or when the power has been turned off.

Color Balance Program

You can also store the color balance setting in memory and recall it when you want to use it.

Note

- You can store up to 3 contents.
- If you want to change the settings, make sure to correctly register them one more time. The previously registered contents will then be changed.

Storing the Adjusted Color Balance

1 Change the color balance.

Reference

⇒ p.94 "Color Balance"



2 Press [Program Color Balance].

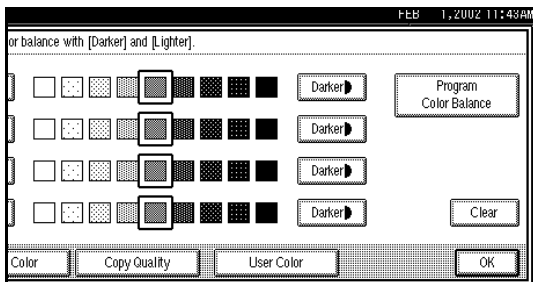

3 Press [Program].

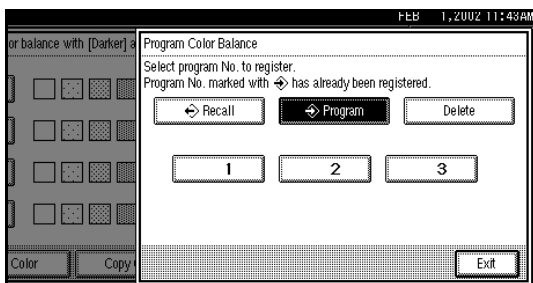

4 Select a number for this setting.

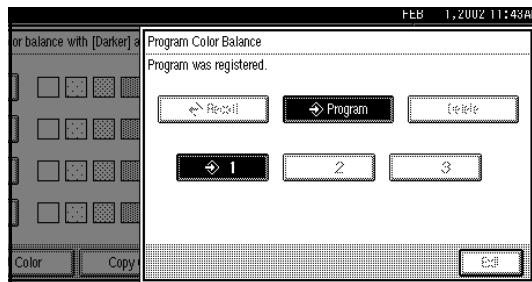

The color balance setting will be registered in the selected number.

 **Note**

- When selecting the program number key displayed on , the registered contents will change.



Overwriting the program

1 Press [Register].

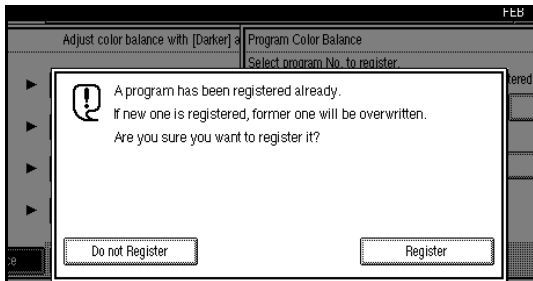

Note

- Press [Do not Register] if you do not want to make any changes.

5 Press [Exit].

Changes in the Registered Contents

1 Press [Program Color Balance].

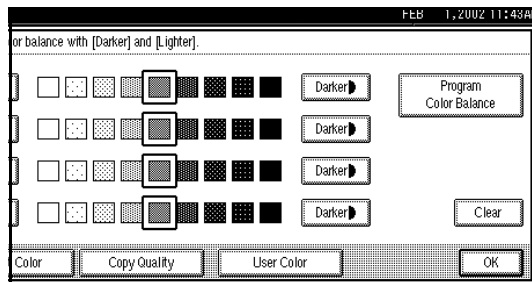

2 Select the program number key displayed on .

The programmed color balance appears.

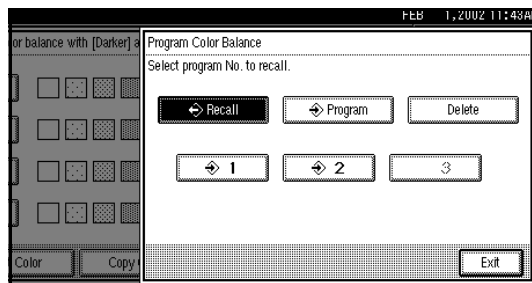



3 Change the registered contents.

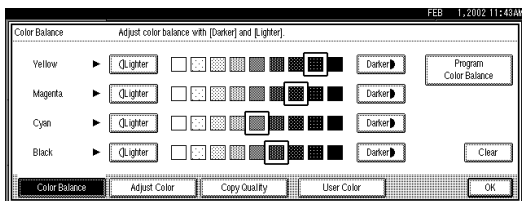

4 When changing the programmed contents, press [Program Color Balance].

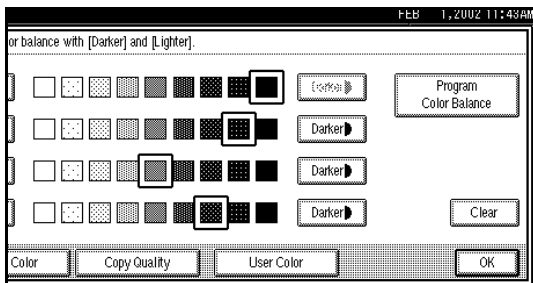

5 Press [Program], and then press the program number key to be overwritten.

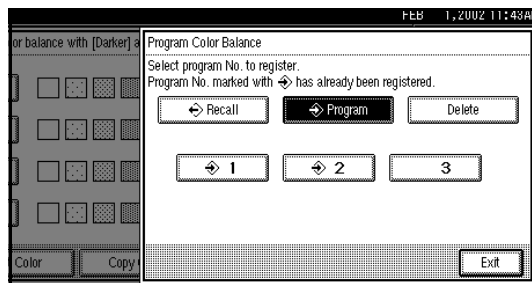

6 Press [Register].

The program is changed.

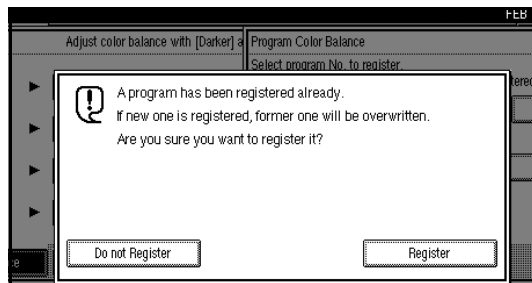

 **Note**

- Press [Do not Register] if you do not want to make any changes.

7 Press [Exit].



Accessing the Registered Contents and Copying it

1 Press the **[Adjust/Program Color]** key.

The **Adjust/Program Color** indicator lights up.

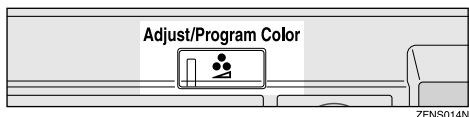

2 Make sure that **[Color Balance]** is selected, and then press **[Program Color Balance]**.

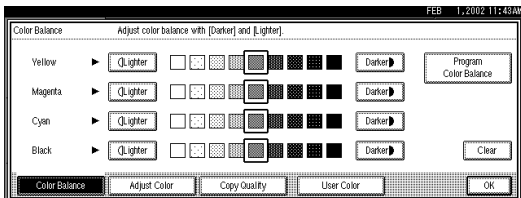

3 Make sure that **[Recall]** has been selected, and then select the program number registered by the color balance to be used.

The programmed color balance appears.

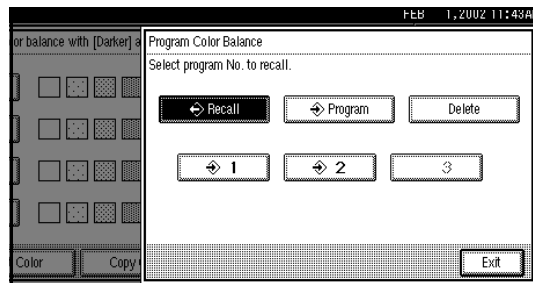

4 Press **[OK]**.

5 Place your originals, and then press the **[Start]** key.

 **Note**

- ❑ After copying has been completed, either performing the Auto Clear function or pressing the **[Clear Modes]** key deletes the recalled contents.



Deleting the Registered Contents

1 Press the **[Adjust/Program Color]** key.

The **Adjust/Program Color** indicator lights up.

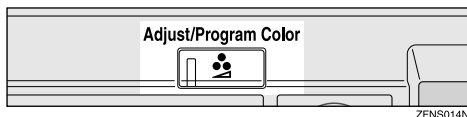

2 Make sure that **[Color Balance]** is selected, and then press **[Program Color Balance]**.

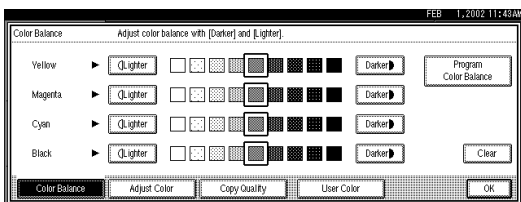

3 Press **[Delete]**, and then select the program number in which the color balance to delete is registered.

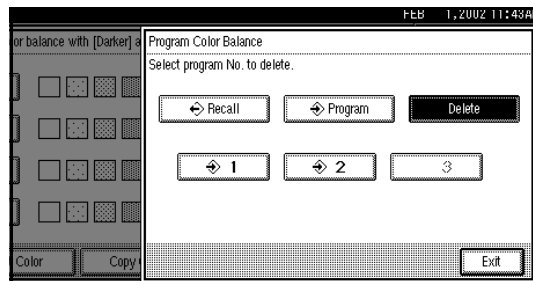

4 Press **[Yes]**.

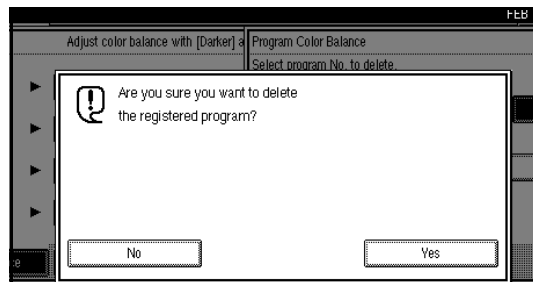

The registered content is deleted.

Note

- Press **[No]** if you do not want to delete anything.

5 Press **[OK]**.

3. User Tools (Copier/Document Server Features)

Accessing the User Tools (Copier/Document Server Features)

This section is for the key operators in charge of this machine. You can change or set the machine's default settings.

Preparation

After using the User Tools, be sure to exit from the User Tools.

The selected key is highlighted.

Any changes you make with the User Tools remain in effect even if the main power switch or operation switch is turned off, or the **[Clear Modes]** key is pressed.

Reference

For details, see “Accessing the User Tools (System Settings)”, Administrator Reference 2 Copier System Edition.

1 Press the **[User Tools/Counter]** key.

The User Tools/Counter menu appears.

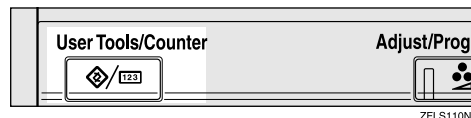

2 Press **[Copier/Document Server Features]**.

The Copier/Document Server Features menu appears.

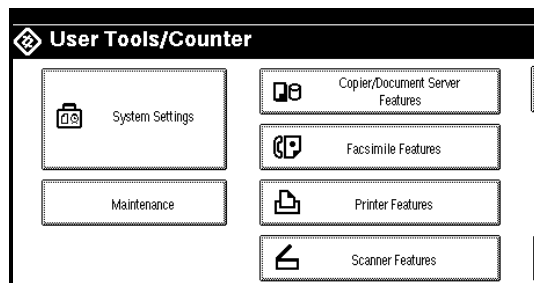

- 3** Select the desired menu, and then press the desired key.

The set screen for each item is displayed.

| Copier/Document Server Features | |
|---------------------------------|--|
| Select items to set. | |
| General Features | Reproduction Ratio |
| Auto Paper Select Priority | ON |
| Paper Display | Display |
| Original Type Display | Display |
| Original Type Priority | Text/Photo |
| Original Photo Type Priority | Text/Photo: Printed Photo / Photo: Printed Photo |

 **Note**

- [▼Next]: Press to go to the next page.
- [▲Previous]: Press to return to the previous page.

- 4** Change the settings by following the instructions on the display panel, and then press [OK].

 **Note**

- [OK]: Press to set the new settings and return to the previous menu.
- [Cancel]: Press to return to the previous menu without changing any data.

Exiting From the User Tools

- 1** After changing the User Tools settings, press [Exit] on the User Tools/Counter menu.

Changing the User Tools is completed, and the machine is ready for copying.

| User Tools/Counter | |
|---------------------------------|-------------|
| Exit | |
| Copier/Document Server Features | Español |
| Facsimile Features | |
| Printer Features | |
| Scanner Features | 123 Counter |

 **Note**

- To cancel any changes and return to Copy mode, press the [User Tools/Counter] key.
- You can also exit from the User Tools by pressing the [User Tools/Counter] key.



General Features ¹/₅

Note

- The screen or the selection items vary depending if the options are installed or not.

❖ Auto Paper Select Priority

As a default setting, Auto Paper Select is selected. You can cancel this setting. ⇒ “Selecting Copy Paper”, *Basic Features* manual

Note

- Default: ON

❖ Paper Display

You can choose whether the available paper trays/sizes are shown on the initial display at Auto Paper Select mode.

Note

- Default: *Display*
- If you choose “Hide”, the display is shown as below. When **[Auto Paper Select]** is pressed, paper sizes appear on the display.

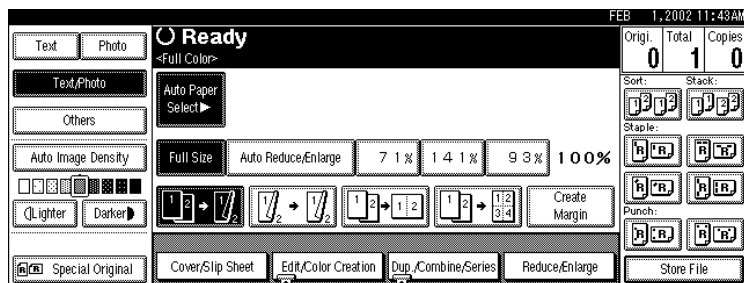



❖ Original Type Display

You can choose whether the original types are shown on the initial display.

Note

- Default: *Display*
- If you choose “Hide”, the display is shown as below.

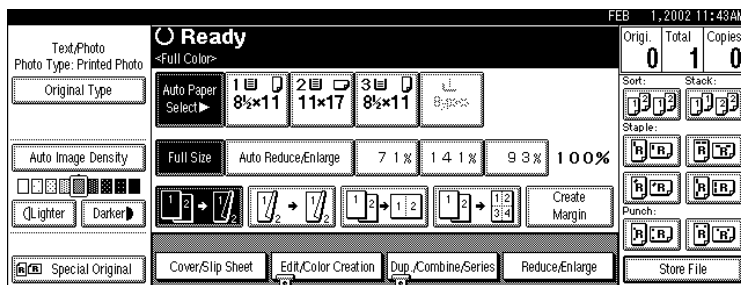

❖ Original Type Priority

As a default setting, Text/Photo is selected as the Originals Type. You can change it to Text, Text/Photo, Photo, Pale, Generation Copy or Map. ⇒ “Selecting Original Type Setting”, *Basic Features* manual

Note

- Default: *Text/Photo*

❖ Original Photo Type Priority

The following types of originals can be set when selecting Text/Photo or Photo:

- Glossy Photo
- Printed Photo
- Copied Photo

 **Note**

- Default:
 - Text/Photo: *Printed Photo*
 - Photo: *Printed Photo*

❖ Auto Tray Switching

If you load paper of the same size in two or more trays, the machine automatically shifts to another tray when the tray in use runs out of paper (when Auto Paper Select is selected.) This function is called “Auto Tray Switching”. This setting specifies whether to use “Auto Tray Switching” or not.

- **[With Image Rotation]**: Use this when copying with Auto Tray Switching.

 **Limitation**

- The machine may not rotate depending on the operating function.
- **[Without Image Rotation]**: Only copies with Auto Tray Switching if you load paper of the same size and in the same direction in two or more trays. If the paper is not the same size or in the same direction, copying is interrupted and the message “Load paper.” is displayed.
- **[OFF]**: When a paper tray runs out of paper, copying is interrupted and the message “Load paper.” is displayed.

 **Note**

- Default: *With image rotation*



General Features ²/₅

❖ Duplex Mode Priority

The optional duplex unit and hard disk unit (40 GB) are required.

You can select the type of Duplex function effective when the machine is turned on, reset, or automatically cleared.

Note

- Default:
 - Metric version: 1 Sided → 1 Sided
 - Inch version: 1 Sided → 2 Sided

❖ Copy Orientation in Duplex Mode

The optional duplex unit and hard disk unit (40 GB) are required.

You can set the copy orientation when making 2 Sided copies.

Note

- Default: *Top to Top*

❖ Original Orientation in Duplex Mode

The optional duplex unit and hard disk unit (40 GB) are required.

You can set the original orientation when making 2 Sided copies.

Note

- Default: *Top to Top*



❖ Change Initial Mode

You can select the standard mode or Program No. 10 as the mode effective when the machine is turned on or modes are cleared.

Note

- Default: *Standard*

❖ Max. Copy Quantity

The maximum copy quantity can be set to 99.

Note

- Default: *99 Sheets*

❖ Tone: Original remains

The beeper (key tone) sounds when you forgot to remove originals after copying.

Note

- Default: *ON*
- If the “Panel Tone” of the User Tools (System Settings) setting is “Off”, the beeper does not sound irrespective of the “Tone: Original remains” setting. ⇒ “Panel Tone”, Administrator Reference 2 Copier System Edition

❖ Job End Call

You can choose whether or not the beeper sounds when copying is complete. If the “Panel Tone” of the User Tools (System Settings) settings is “On”, the machine beeps to notify you that the machine did not complete a job for reasons such as copying was interrupted, the paper tray ran out of paper or a paper jam occurred.

Note

- Default: *ON*



General Features ³/₅

❖ Copy Function Key: F1-F5

The optional document feeder (ADF), 2 Tray Finisher and hard disk unit (40 GB) are required.

You can register frequently used functions in Function Keys F1 to F5.

Note

Default:

- When the machine does not have Duplex function;
 - Copy Function Key: F1: *1 Sided→1 Sided Combine*
 - Copy Function Key: F2: *1 Sided→1 Sided Combine: 4 originals*
 - Copy Function Key: F3: *1 Sided→1 Sided Combine: 8 originals*
 - Copy Function Key: F4: *None*
 - Copy Function Key: F5: *Create Margin*
- When the machine has Duplex function;
 - Copy Function Key: F1: *1 Sided→2 Sided: T to T*
 - Copy Function Key: F2: *2 Sided: T to T→2 Sided: T to T*
 - Copy Function Key: F3: *1 Sided→1 Sided Combine*
 - Copy Function Key: F4: *1 Sided→1 Sided Combine: 4 originals*
 - Copy Function Key: F5: *Create Margin*



General Features ⁴/₅

❖ Document Server Storage Key: F1–F5

You can register frequently used functions in Function keys F1 to F5. You can also change the registered functions.

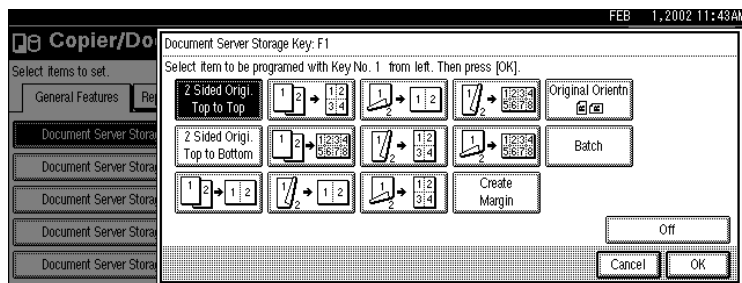

Note

Default

- Document Server Storage Key: F1: 2 Sided Original Top to top
- Document Server Storage Key: F2: 1 Sided → 1 Sided Combine
- Document Server Storage Key: F3: 1 Sided → 1 Sided Combine: 4 originals
- Document Server Storage Key: F4: 1 Sided → 1 Sided Combine: 8 originals
- Document Server Storage Key: F5: Create Margin



General Features ⁵/₅

❖ Clear Bypass Mode

Set this function to whether or not the settings of the Bypass Tray are cleared, when performing Auto Clear after turning the power on or when performing reset.

Note

- Default: *Clear*

❖ Color Mode Priority

Set this function to whether or not copy by prioritizing either “Black & White” or “Full Color”.

Note

- Default: *Full Color*

❖ Two-color Mode Priority

Set this function to whether or not to prioritize “Red & Black” or “Two-color” when using the “Two-color” modes.

Note

- Default: *Red & Black*

❖ Auto Image Density Priority

Set this function to whether or not use Automatic Density, when performing Auto Clear after turning the power on or when performing reset.⇒ “Auto Image Density”, *Basic Features* manual

Note

- Default
 - Full Color / Two-color: *OFF*
 - B & W / Single Color: *ON*



Reproduction Ratio $1/2$

❖ Shortcut R/E

You can register up to three frequently used Reduce/Enlarge ratios other than the fixed Reduce/Enlarge ratio and have them shown on the initial display. You can also change the registered Reduce/Enlarge ratios.

Note

Default:

- Metric version:
 - Shortcut R/E 1: 71%
 - Shortcut R/E 2: 141%
 - Shortcut R/E 3: 93%
- Inch version:
 - Shortcut R/E 1: 73%
 - Shortcut R/E 2: 155%
 - Shortcut R/E 3: 93%



❖ Enlarge 1-5

You can customize the enlargement ratios available when you press **[Reduce/Enlarge]** followed by **[Enlarge]**.

Note

Default:

- Metric version:
 - Enlarge 1: 115%
 - Enlarge 2: 122%
 - Enlarge 3: 141%
 - Enlarge 4: 200%
 - Enlarge 5: 400%
- Inch version:
 - Enlarge 1: 121%
 - Enlarge 2: 129%
 - Enlarge 3: 155%
 - Enlarge 4: 200%
 - Enlarge 5: 400%

When selecting **[User Enlrg. Ratio]**, enter a ratio using the number keys (in the range of 101 to 400%).

❖ Priority Setting: Enlarge

You can set the ratio with priority when **[Reduce/Enlarge]** is pressed, followed by **[Enlarge]**.

Note

Default:

- Metric version: 141%
- Inch version: 155%





Reproduction Ratio $2/2$

❖ Reduce 1-6

You can customize the reduction ratios available when you press **[Reduce/Enlarge]** followed by **[Reduce]**.

Note

Default:

- Metric version:
 - Reduce 1: 25%
 - Reduce 2: 50%
 - Reduce 3: 65%
 - Reduce 4: 71%
 - Reduce 5: 75%
 - Reduce 6: 82%
- Inch version:
 - Reduce 1: 25%
 - Reduce 2: 50%
 - Reduce 3: 65%
 - Reduce 4: 73%
 - Reduce 5: 78%
 - Reduce 6: 85%

When selecting **[User Redc.Ratio]**, enter a ratio using the number keys (in the range of 25 to 99%).



❖ Priority Setting: Reduce

You can set the ratio with priority when **[Reduce/Enlarge]** is pressed, followed by **[Reduce]**.

Note

Default:

- Metric version: 71%
- Inch version: 73%

❖ Ratio for Create Margin

You can set a Reduce/Enlarge ratio when registering “Create Margin” in a Shortcut Key.

Note

Default: 93%

❖ R/E Priority

Specify whether Reduce, Enlarge or Input Ratio is given priority on the display panel when **[Reduce/Enlarge]** is pressed.

Note

Default: *Reduce*



Edit 1/2

❖ Front Margin: Left/Right

You can specify left and right margins on the front side of copies in Margin Adjust mode.

Note

- Default:
 - Metric version: *Left 5mm*
 - Inch version: *Left 0.2"*

❖ Back Margin: Left/Right

You can specify left and right margins on the back side of copies in Margin Adjust mode.

Note

- Default:
 - Metric version: *Right 5mm*
 - Inch version: *Right 0.2"*

❖ Front Margin: Top/Bottom

You can specify front top and bottom margins on the front side of copies in Margin Adjust mode.

Note

- Default:
 - Metric version: *T/B 0mm*
 - Inch version: *T/B 0.0"*





❖ **Back Margin: Top/Bottom**

You can specify top and bottom margins on the back side of copies in Margin Adjust mode.

Note

Default:

- Metric version: *T/B 0mm*
- Inch version: *T/B 0.0"*

❖ **1 sided→2 sided Auto Margin:T to T**

The optional duplex unit and hard disk unit (40 GB) are required.

In 1 sided → 2 sided Duplex mode, you can specify whether to automatically set the margins on the back side.

The margin is set to the same value of “Back Margin: Left/Right”.

Note

Default:

- Metric version: *Right 5mm*
- Inch version: *Right 0.2"*

❖ **1 Sided→2 Sided Auto Margin: TtoB**

The optional duplex unit and hard disk unit (40 GB) are required.

In 1 sided → 2 sided Duplex mode, you can specify whether to automatically set the margins on the back side. The value set for “Back Margin: Top/Bottom” is used.

Note

Default:

- Metric version: *T/B 0mm*
- Inch version: *T/B 0.0"*



❖ Erase Border Width

The default setting of the width of the erased margins in Erase Border mode can be changed as follows:

- Metric version: 2 – 99mm in 1mm steps
- Inch version: 0.1" – 3.9" in 0.1" steps

Note

Default:

- Metric version: *10mm*
- Inch version: *0.4"*

❖ Erase Original Shadow in Combine

In Combine Copy mode, you can specify whether to erase a 3mm, 0.1" bounding margin around all four edges of each original.

Note

Default: Yes

❖ Erase Center Width

The default setting of the width of the erased margins in Erase Center mode can be changed as follows:

- Metric version: 2 – 99mm in 1mm steps
- Inch version: 0.1" – 3.9" in 0.1" steps

Note

Default:

- Metric version: *10mm*
- Inch version: *0.4"*





Edit ²/₂

❖ Front Cover Copy in Combine

You can specify whether to make a combined copy on the front cover sheet when you select Front Cover Copy mode.

| Combine | | | | Not Combined | | | | |
|---------|---|---|---|--------------|---|---|---|---|
| 1 | 2 | 5 | 6 | 1 | 2 | 3 | 6 | 7 |
| 3 | 4 | 7 | 8 | | 4 | 5 | 8 | |

GCCOMB0E

Note

Default: *Combine*





❖ Copy Order in Combine

You can set the copy order in Combine mode to “Left to Right” or “Top to Bottom”.

| From Left to Right | From Top to Bottom | | | | | | | | | | | | | | | | |
|--|--------------------|---|---|---|--|---|---|---|--|---|---|---|---|---|---|---|---|
| <table border="1"><tr><td>1</td><td>2</td></tr><tr><td>3</td><td>4</td></tr></table> | 1 | 2 | 3 | 4 | <table border="1"><tr><td>1</td><td>3</td></tr><tr><td>2</td><td>4</td></tr></table> | 1 | 3 | 2 | 4 | | | | | | | | |
| 1 | 2 | | | | | | | | | | | | | | | | |
| 3 | 4 | | | | | | | | | | | | | | | | |
| 1 | 3 | | | | | | | | | | | | | | | | |
| 2 | 4 | | | | | | | | | | | | | | | | |
| <table border="1"><tr><td>1</td><td>2</td><td>3</td><td>4</td></tr><tr><td>5</td><td>6</td><td>7</td><td>8</td></tr></table> | 1 | 2 | 3 | 4 | 5 | 6 | 7 | 8 | <table border="1"><tr><td>1</td><td>3</td><td>5</td><td>7</td></tr><tr><td>2</td><td>4</td><td>6</td><td>8</td></tr></table> | 1 | 3 | 5 | 7 | 2 | 4 | 6 | 8 |
| 1 | 2 | 3 | 4 | | | | | | | | | | | | | | |
| 5 | 6 | 7 | 8 | | | | | | | | | | | | | | |
| 1 | 3 | 5 | 7 | | | | | | | | | | | | | | |
| 2 | 4 | 6 | 8 | | | | | | | | | | | | | | |

GCAH090E

Note

- Default: *From Left to Right*

❖ Image Repeat Separation Line

You can select a separation line in Image Repeat mode from None, Solid, Broken A, Broken B or Crop Marks. ⇒ [p.35 “Image Repeat”](#).

- None





- Solid



- Broken A



- Broken B



- Crop Marks



Note

- Default: *None*
- Line Color (Full Color): Yellow, Red, Cyan, Magenta, Green, Blue, Black
- Separation lines cannot be specified when using **[None]**.
- In “Black and White”, printing will be done in black; in “Single Color”, printing will be done in the specified color; in “Two-color” (standard), printing will be done in the specified color of the black area; and in “Two-color” (Red and Black), printing will be done in black.
- An image of approximately 1.5mm (0.06”) will not be displayed as the width of the separation line, when specifying solid or broken lines.





❖ Double Copies Separation Line

You can select a separation line in Double Copy mode from None, Solid, Broken A, Broken B or Crop Marks. ⇒ p.40 “Double Copies”

- None



- Solid



- Broken A



- Broken B



- Crop Marks



Note

- Default: *None*
- Line Color (Full Color): Yellow, Red, Cyan, Magenta, Green, Blue, Black
- Separation lines cannot be specified when using **[None]**.





- In “Black and White”, printing will be done in black; in “Single Color”, printing will be done in the specified color; in “Two-color” (standard), printing will be done in the specified color of the black area; and in “Two- color” (Red and Black), printing will be done in black.
- An image of approximately 1.5mm (0.06”) will not be displayed as the width of the separation line, when specifying solid or broken lines.

❖ Separation Line in Combine

You can select a separation line in Combine mode from None, Solid, Broken A, Broken B or Crop Marks. ⇒“Combine”, *Basic Features* manual

- None



- Solid



- Broken A



- Broken B





- Crop Marks



Note

- Default: *None*
- Line Color (Full Color): Yellow, Red, Cyan, Magenta, Green, Blue, Black
- Separation lines cannot be specified when using **[None]**.
- In “Black and White”, printing will be done in black; in “Single Color”, printing will be done in the specified color; in “Two-color” (standard), printing will be done in the specified color of the black area; and in “Two- color” (Red and Black), printing will be done in black.
- An image of approximately 1.5mm (0.06”) will not be displayed as the width of the separation line, when specifying solid or broken lines.





Input/Output

❖ Switch to Batch

The optional document feeder (ADF) is required.

You can select whether Batch mode or SADF mode is displayed when the machine is turned on, reset, or automatically cleared.

Note

- Default: *Batch (SADF)*

❖ SADF Auto Reset

The optional document feeder (ADF) is required.

When you place one original at a time in the optional document feeder (ADF), the Auto Feed indicator lights for a selected time after an original is fed to show that the optional document feeder (ADF) is ready for another original. You can adjust this time from 3 seconds to 99. ⇒ “SADF Mode”, *Basic Features* manual

Note

- Default: *5 seconds*

❖ Rotate Sort: Auto Paper Continue

The optional hard disk unit (40 GB) is required.

You can specify whether to continue copying when the paper of the required orientation has run out during rotate-sorting. ⇒ “Sort”, *Basic Features* manual

- If you select **[No]**:

When paper of the required orientation runs out, the machine stops copying and prompts you to supply copy paper. When you load paper, the machine will continue copying.



- If you select **[Yes]**:
Copying continues using copy paper of a different orientation. The copy job will finish even if you have left the machine.

 **Note**

Default: No

❖ **Auto Sort**

The optional hard disk unit (40 GB) is required.

You can specify whether Sort mode is selected when the machine is turned on or the mode is cleared.

 **Note**

Default: No

❖ **Memory Full Auto Scan Restart**

The optional hard disk unit (40 GB) is required.

When the memory becomes full while scanning originals, the machine can make copies of the scanned originals first, and then automatically proceed scanning the remaining originals.

You can enable or disable this function.

- If you select **[No]**:
When the memory becomes full, the machine stops operation allowing you to remove the copy pages delivered on the output tray.
- If you select **[Yes]**:
You can leave the machine unattended to make all the copies, but the resulting sorted pages will not be sequential.

 **Note**

Default: No





❖ Select Stack Function

The optional 2 Tray Finisher and hard disk unit (40 GB) are required.

Specify whether Stack or Rotate Sort has priority to be shown on the initial display.

Note

Default: *Stack*

❖ Select Stapling Position

The optional 2 Tray Finisher is required.

Specify whether Top 2 staples or Bottom is shown on the initial display with priority.

Note

Default: *Top 2 staples*

❖ Letterhead Setting

If you want to copy on the direction-fixed (top to bottom) or 2 sided paper, the machine rotates the image correctly. To use this function, select “Yes”.⇒ [p.137 “Letterhead”](#)

Note

Default: *No*





Adjust Color Image

❖ Background Density of ADS(Full Color / Two-color)

The background density is adjusted to skip the texture and copy. You can adjust the background density up to 5 levels when in Full Color or Two-color.

- Adjust by pressing “Lighter” or “Darker”.

Note

- Default: *Center of the 5 level adjustment*

❖ Color Sensitivity

You can adjust the tone of red in “Two color (Red & Black)” and the color specified for “Erase Color”, in 5 levels.









Note

- When the color width has been set to “Wider”, and the color to be deleted, for example is red, all the colors that are close to magenta and orange are deleted. If it's set to “Narrower” the color red will be deleted.
 - Adjust by pressing “Narrower” or “Wider”.
- Default: *Center of the 5 level adjustment*















4. Specifications

Mainframe

- ❖ **Original scanning:**
One-dimensional solid scanning system through CCD
- ❖ **Original copying:**
One-dimensional solid copying system through laser beam (Black, Yellow, Cyan, Magenta)
- ❖ **Copy process:**
Dry electrostatic transfer system
- ❖ **Warm-up time:**
Less than 119 seconds (23°C)
- ❖ **Originals:**
Sheet/book/objects
- ❖ **Maximum original size:**
A3 , 11" × 17" 
- ❖ **Copy paper size:**
A3  – B5  , 11" × 17"  – 5¹/₂" × 8¹/₂"  
- ❖ **Non-reproduction area:**
Leading/Trailing/Left/Right edge: Less than 4.2mm



❖ **Copying speed:**

| | Normal |
|-----------------|--|
| Full Color | 28 copies/minute (A4  , 8 1/2" × 11" ) |
| | 14 copies/minute(A3  , 11" × 17" ) |
| Black & White | 38 copies/minute (A4  , 8 1/2" × 11" ) |
| | 18 copies/minute(A3  , 11" × 17" ) |
| Two color (RGB) | 28 copies/minute (A4  , 8 1/2" × 11" ) |
| | 14 copies/minute(A3  , 11" × 17" ) |

❖ **Reproduction ratio:**

Preset reproduction ratios:

| | Metric version | Inch version |
|-------------|-----------------------|---------------------|
| Enlargement | 400% | 400% |
| | 200% | 200% |
| | 141% | 155% |
| | 122% | 129% |
| | 115% | 121% |
| Full Size | 100% | 100% |



| | Metric version | Inch version |
|-----------|-----------------------|---------------------|
| Reduction | 82% | 85% |
| | 75% | 78% |
| | 71% | 73% |
| | 65% | 65% |
| | 50% | 50% |
| | 25% | 25% |

Zoom: From 25 to 400% in 1% steps.

❖ **Maximum continuous copy run:**

99 sheets

❖ **Power consumption:**

Less than 1.5 Kw





Originals

Sizes and Weights of Recommended Originals

❖ Metric version

| Where Original Is Placed | Original Size | Original Weight |
|--------------------------------|--------------------------------|--------------------------|
| Exposure glass | Up to A3 | -- |
| Optional document feeder (ADF) | 1-sided originals: A3 – A5 | 60 – 128g/m ² |
| | 2-sided originals: A3 – B5 | 60 – 105g/m ² |

❖ Inch version

| Where Original Is Placed | Original Size | Original Weight |
|--------------------------------|--|-----------------|
| Exposure glass | Up to 11" × 17" | -- |
| Optional document feeder (ADF) | 1-sided originals: 11" × 17" – 5½" × 8½" | 16 – 34 lb. |
| | 2-sided originals: 11" × 17" – 5½" × 8½" | 16 – 28 lb. |

Note

- The number of originals that can be placed in the optional document feeder (ADF) is about 80.
- Original weight in Mixed Size mode is 60-81g/m², 16-21.5 lb.



Sizes Detectable by the Auto Paper Select

◆ Metric version

| Size | A3 | B4 | A4 | B5 | A5 | 11" × 17" | 8½" × 13" | 8½" × 11" | 8" × 13" | 8K | 16K |
|--------------------------------|--------|--------|--------|--------|--------|---------------|---------------|---------------|--------------|--------|---------|
| Exposure glass | ○ | ○ | ○ | ○ | × | × | × | × | ○ | × | × |
| Optional document feeder (ADF) | ○ | ○ | ○ | ○ | ○ | × | ○ | × | × | ○ | ○ |

○: Auto detect

×: Unable to auto detect

Note

- If you want the machine to detect sizes 11" × 17"
 instead of 8K (267mm × 389mm), and 16K (195mm × 267mm) instead of A4 , contact your nearest service representative.



❖ Inch version

| Size | A3 ☐ | B4 ☐ | A4 ☐ | B5 ☐☐ | A5 ☐☐ | 11" × 17"☐ | 10" × 14"☐ | 8" × 13"☐ | 8½" × 14"☐ | 8½" × 11"☐☐ | 5½" × 8½"☐☐ | US EXE☐ |
|---|---------|---------|---------|----------|----------|---------------|---------------|--------------|---------------|----------------|----------------|------------|
| Exposure glass | × | × | × | × | × | ○ | × | ○ | ○ | ○ | × | × |
| Optional document feeder (ADF) | × | × | ○ | × | × | ○ | ○ | × | ○ | ○ | ○ | ○ |

○: Auto detect

×: Unable to auto detect

📌 Note

- ☐ If you want the machine to detect sizes US EXE ☐ instead of 8 ½" × 11" ☐; 8" × 10"☐ instead of 8 ½" × 11" ☐; 8 ½" × 13" ☐ instead of 8 ½" × 14"☐; or 11" × 15" ☐ instead of 11" × 17"☐, contact your nearest service representative.

❖ Exposure glass

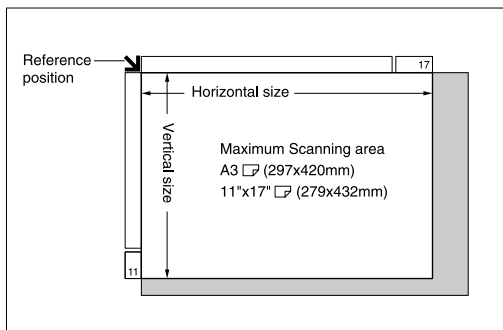



❖ **Optional document feeder (ADF)**

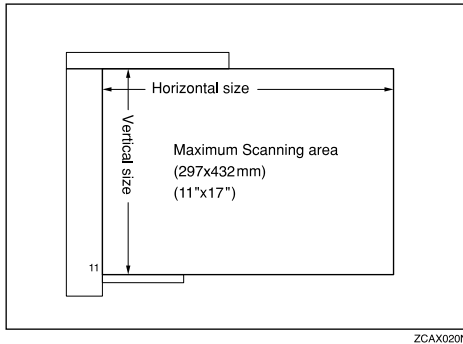

Area Where Images are not Copied

The number of millimeters inside the area surrounding the original will not be copied.

❖ **Area where the original is not copied (when using A3 or 11"x17")**

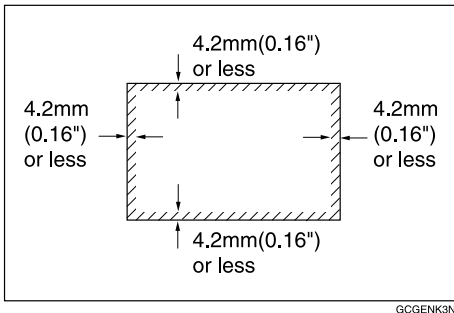



Non-recommended Originals for the Optional Document Feeder (ADF)

Setting the following types of originals in the optional document feeder (ADF) can cause paper mis-feeds or damage to the originals. Place these originals on the exposure glass instead.

- Originals other than those specified in ⇒ p.131 “[Sizes and Weights of Recommended Originals](#)”
- Stapled or clipped originals
- Perforated or torn originals
- Curled, folded, or creased originals
- Pasted originals
- Originals with any kind of coating, such as thermal fax paper, art paper, aluminum foil, carbon paper, or conductive paper
- Originals with perforated lines
- Originals with indexes, tags, or other projecting parts
- Sticky originals such as translucent paper
- Thin originals that have low stiffness
- Thick originals such as postcards
- Bound originals such as books
- Transparent originals such as OHP transparencies or translucent paper
- Originals that have correction fluid or ink on them that has not completely dried



Sizes Difficult to Detect

As the machine cannot detect the sizes of the following originals, the paper size should be selected manually.

- Originals with indexes, tags, or other projecting parts
- Transparent originals such as OHP transparencies or translucent paper
- Dark originals with many letters and drawings
- Originals which contain partially a solid image
- Originals which have solid images at their edges





Letterhead

It is possible that doubled sided paper or top and bottom margins on letterhead paper or business letter paper might not be printed correctly depending on the combination of the paper placed or original placed. Make sure to place the paper or originals as follows by setting the “Letterhead Setting” to “Yes”.

| | | Set place | | Bypass Tray | |
|-------------|---------|---------------|------------|----------------|--------------------------------|
| | | Standard Tray | Paper Bank | Exposure Glass | Optional Document Feeder (ADF) |
| Copy mode | | | | | |
| Orientation | 1 Sided | | | | |
| | 2 Sided | | | — | — |
| Orientation | 1 Sided | | — | | |
| | 2 Sided | | — | — | — |

*1 When the paper size has been specified.





INDEX

A

Adjust Color, 92
Auto Color Calibration, 88
Auto Start, 68

B

Border Erase, 25, 26

C

Center/Border Erase, 25, 29
Center Erase, 25, 28
Centering, 42
Changing a Program's Name, 58
Color Balance, 94
 Color Balance Program, 95
Combination Chart, 72
Copy Quality, 85
 Adjusting the Background Density, 87
 Adjusting the Contrast, 86
 Adjusting the Sharp/Soft, 86
 Adjusting the Text/Photo Sensitivity, 88
 Adjusting the U.C.R., 87
Cover, 44
 Front/Back Covers, 46
 Front Cover, 44

D

Directional Magnification (%), 14
Directional Size Magnification (mm), 17
Double Copies, 40

E

Energy Saver mode, 68
Erase, 25
 Border, 25, 26
 Center, 25, 28
 Center/Border, 25, 29
Erasing Colors, 23
Exposure glass, 133

I

Image Repeat, 35
 Specified Area Repeat, 37
 Whole Area Repeat, 36
Interrupt Copy, 69

J

Job Preset, 66

L

Letterhead, 137



M

Margin Adjustment, 32

N

Notice, 7

O

Originals, 131

P

Program

Changing, 55

Deleting, 56

Recalling, 57

Storing, 54

Programs, 53

S

Sample Copy, 70

Series, 20

Series Copies, 20

Slip Sheets, 49

Specifications, 128

Storing the File in the Document Server, 51

T

Troubleshooting, 74

If You Cannot Make Clear Copies, 74

If You Cannot Make Copies As You Want, 79

When copying doesn't start, 77

U

User Color, 59

Deleting, 64

Sampling, 65

User Tools (Copier/Document Server Features), 101

Accessing, 101

Adjust Color Image, 127

Edit 1/2, 115

Edit 2/2, 118

Exiting, 102

General Features 1/5, 103

General Features 2/5, 106

General Features 3/5, 108

General Features 4/5, 109

General Features 5/5, 110

Input/Output, 124

Reproduction Ratio 1/2, 111

Reproduction Ratio 2/2, 113



In accordance with IEC 60417, this machine uses the following symbols for the main power switch:

- ⏻ means **POWER ON.**
- ⏻ means **POWER OFF.**
- ⏻ means **STAND-BY.**

